

VARIABLE
DISPLACEMENT
AXIAL PISTON
PUMPS

MVP

FEATURES

Variable displacement axial piston pumps swash plate design ideally suited for medium and high pressure open circuit applications. The compact design allows to be mounted directly on engine motors.

DISPLACEMENTS

From 28 cm³/rev (1.74 in³/rev)
To 84,7 cm³/rev (5.17 in³/rev)

PRESSURE

Max. continuous 280 bar (4060 psi)
Max. intermittent 315 bar (4568 psi)
Max. peak 350 bar (5075 psi)

SPEED

Max. 3500 min⁻¹

APPLICATION

Medium, high pressure

SECTOR

Mobile

TYPICAL APPLICATIONS

- Skid Steer Loaders
- Wheel Loaders-Backhoe Loaders
- Mini and Midi-Excavators
- Asphalt Pavers
- Telehandlers
- Forklifts
- Windmills-Green Energy
- Turf Care

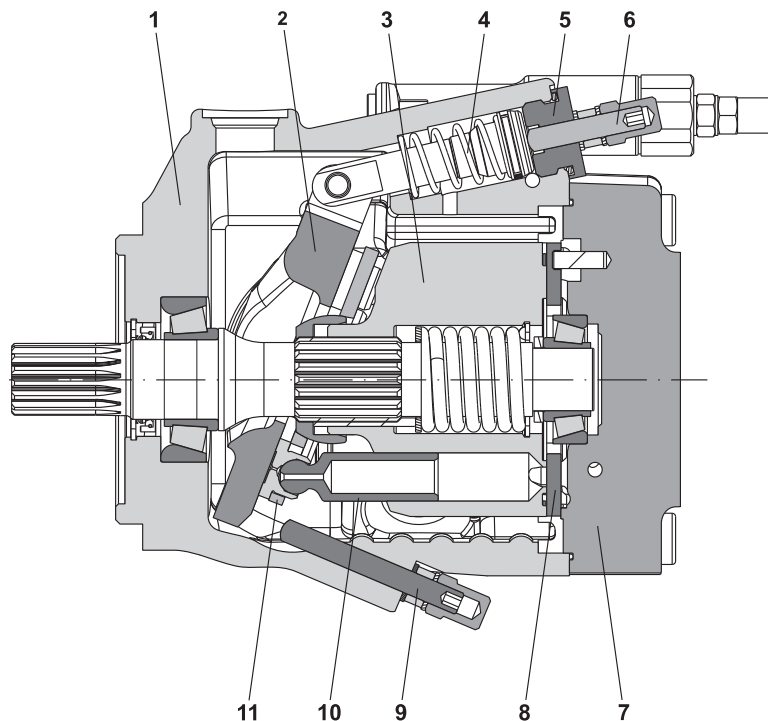

1	Pump body
2	Swash plate
3	Cylinders block
4	Counterbalancing spring
5	Plug
6	Max. displacement limiter
7	Cover
8	Valve plate
9	Min. displacement limiter
10	Piston
11	Piston guide plate

- Compact design
- Longer service life
- Low noise emission
- Max. and min. displacement limiter

- Drive shaft bearing suitable for radial and axial loads
- Hydraulic and Electro-hydraulic displacement controls

○ Modification from former edition.

Replaces: 03/06.2011

○ 04/01.2012

GENERAL INFORMATION / INSTRUCTIONS

DIRECTION OF ROTATION

Clockwise or anti-clockwise defined looking at the drive shaft.

HYDRAULIC FLUID

Mineral oil based hydraulic fluid conforming to DIN 51524, fire resistant fluids and biodegradable fluids according to the technical data shown in the tables on pages 5 ÷ 7. The system should be designed to prevent aeration of the hydraulic fluid.

FLUID VISCOSITY

The fluid viscosity range for optimal use of MVP pump is between 15 and 35 cSt (77 and 163 SSU).

Functional limit conditions are:

max.: 1500 cSt (6818 SSU) at start up at -25 °C (-13 °F) with straight and short inlet line.

min.: 10 cSt (58 SSU) at maximum temperature of 110 °C (230 °F)

FILTRATION

To ensure the optimal performance and the maximum life to the pump, the hydraulic fluid must have and maintain a fluid contamination within the values shown in the table below.

Working pressure bar (psi)	$\Delta p < 140$ (2030)	$140 < \Delta p < 210$ (2030) (3045)	$\Delta p > 210$ (3045)
Contamination class NAS 1638	9	8	7
Contamination class ISO 4406:1999	20/18/15	19/17/14	18/16/13
Achieved with filter $B_{x(c)} \geq 75$ according to ISO 16889	10 μm	10 μm	10 μm

Casappa recommends to use its own production filters:



INSTALLATION

Check that the maximum coupling eccentricity stays within 0,25 mm (0.0098 in) to reduce shaft loads due to misalignment. It is advised to use a flexible coupling suitable to absorb eventual rotational shocks. For applications with axial and radial loads exceeding published standards, consult our sales department. The direction of rotation of the pump must agree with the prime mover rotation. Before installation, the case of the pump must be filled with fluid.

LINES

The lines must have a major diameter which is at least as large as the diameter of pump ports, and must be perfectly sealed. To reduce loss of power, the lines should be as short as possible, reducing the sources of hydraulic resistance (elbow, throttling, gate valves, etc.) to a minimum. A length of flexible tubing is recommended to reduce the transmission of vibrations.

Before connecting the lines, remove any plug and make sure that the lines are perfectly clean. Check that the drain line is dimensioned in a way to guarantee a case pressure lower than 1,5 bar (22 psi) absolute. The drain line must be connected directly (no filter, no valves, no oil cooler) to the tank and must terminate below the oil level. Check that the dimensions of the suction line guarantee a pressure equal or superior to 0,8 bar (24 in Hg). Inlet pressure less than 0,8 bar (24 in Hg) could cause an increase of noise emission, the decrease of the pump performances and a reduction of its life expectancy.

STARTING UP

Check that all connections are secure and that the entire system is completely clean. Add oil to the tank always using a filter. Bleed the air from the circuit to help the filling. Turn on the system for a few moments at minimum speed, then bleed the circuit again and check the level of oil in the tank. Gradually increase the pressure and speed of rotation up to the pre-set operating levels, which must stay within the stated limits as specified in the catalogue.

FOR VERY LOW TEMPERATURE

STORAGE

No problem in case of temperature down to -30°C (-22°F). Down to -40°C (-40°F) some micro cracks in the shaft seal lip have been experienced. Below -40°C (-40°F) please consult our technical-sales department.

STARTING UP

We strongly recommend to warm up the oil before running the machine. If this is not possible, the warm up of the oil and of the pump should be carried out following these instructions:

- Start the pump in stand-by condition at minimum speed. Keep this working condition until the pump case reaches -20°C (-4°F)
- Increase slowly the displacement. Max pressure permitted: 50 bar (725 psi). The maximum permitted speed is strictly connected to the layout of the inlet circuit; check that there is no cavitation before increasing the speed.
- Keep this working condition until the oil temperature in the whole system is -10°C (14°F).
- Maximum pressure can be achieved from now on.
- Always check the outlet flow to prevent cavitation damage.

All the temperature are referred to oil with viscosity ISO VG 32 according to DIN 51 519.

SUGGESTIONS

To prevent cavitation at low temperature we suggest:

- To warm up the tank
- To pressurize the tank
- To oversize the inlet hose

03/06.2011

MOUNTING POSITIONS

Standard pump is supplied with the D1 drain hole open and D2, D3, D4 plugged.

Before installation fill the pump with hydraulic oil for at least 3/4 of the volume keeping it in horizontal position.

The pump can be mounted in a horizontal or vertical position. The highest of the case drain ports must be used to keep the required filling oil.

If D1 is not the highest drain port it must be closed by moving the plug from the hole chosen for the drain line.

The pump can be located above the oil level if the absolute pressure at the inlet port stays within the stated limits.

With exception of pump mounted below the oil level, we recommend to interpose a baffle plate between inlet and drain line.

To reduce further noise emission, we recommend to mount the pump below the oil level and avoid suction lines with sharp restrictions.

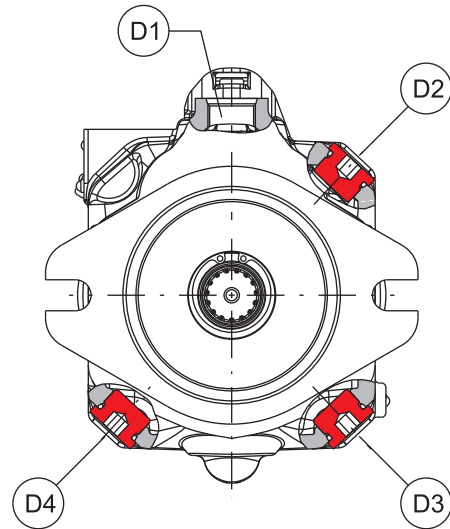

HORIZONTAL MOUNTING		VERTICAL MOUNTING	
	<p>Arrangement inside the tank.</p> <p>Minimum oil level equal or above the pump mounting face.</p> <p>A ≥ 200 mm (7.874 in)</p>		<p>Arrangement inside the tank.</p> <p>Minimum oil level equal or above the pump mounting face.</p> <p>A ≥ 200 mm (7.874 in)</p>
	<p>Arrangement inside the tank.</p> <p>Minimum oil level below the pump mounting face.</p> <p>Min. inlet pressure= 0,8 bar abs (24 in Hg)</p> <p>B ≤ 800 mm (31.4961 in)</p> <p>C = 200 mm (7.874 in)</p>		<p>Arrangement inside the tank.</p> <p>Minimum oil level below the pump mounting face.</p> <p>Min. inlet pressure= 0,8 bar abs (24 in Hg)</p> <p>B ≤ 800 mm (31.4961 in)</p> <p>C = 200 mm (7.874 in)</p>
	<p>Arrangement outside the tank above oil level.</p> <p>Min. inlet pressure= 0,8 bar abs (24 in Hg)</p> <p>B ≤ 800 mm (31.4961 in)</p> <p>C = 200 mm (7.874 in)</p>		<p>Arrangement outside the tank above oil level.</p> <p>Min. inlet pressure= 0,8 bar abs (24 in Hg)</p> <p>B ≤ 800 mm (31.4961 in)</p> <p>C = 200 mm (7.874 in)</p>
	<p>Arrangement outside the tank below oil level.</p> <p>C = 200 mm (7.874 in)</p>		

IN= inlet line - D1= drain line - A= min. distance between the line - B+C= permissible suction height - C= line immersion depth

03/06.2011

TECHNICAL DATA

Technical data with mineral oil

HL or HLP mineral oil based hydraulic fluid to DIN 51524

Pump type MVP			30-28	30-34	48-45	48-53	60-60	60-72	60-84
Max. displacement (theor.) V_{max}	cm ³ /rev (in ³ /rev)		28 (1.74)	34,8 (2.12)	45 (2.75)	53,7 (3.28)	60 (3.66)	72 (4.39)	84,7 (5.17)
	Inlet pressure	bar abs. (in Hg)	min.				0.8 (24)		
bar abs. (psi)		max.				25 (363)			
Max. outlet pressure p_{max}	bar (psi)	continuous	280 (4060)	250 (3625)	280 (4060)	250 (3625)	280 (4060)	280 (4060)	250 (3625)
		intermittent	315 (4568)	280 (4060)	315 (4568)	280 (4060)	315 (4568)	315 (4568)	280 (4060)
		peak	350 (5075)	315 (4568)	350 (5075)	315 (4568)	350 (5075)	350 (5075)	315 (4568)
Max. drain line pressure	bar abs. (psi)					1,5 (22)			
Max. speed n_{max}	min ⁻¹	@ V_{max} (1)	3500	2900	3000	2500	3000	2700	2300
		@ n_{max}	98 (25.9)	101 (26.7)	135 (35.7)	134 (35.4)	180 (47.6)	194 (51.3)	195 (51.5)
Max. delivery (theor.)	l/min (US gpm)	@ 2000 min ⁻¹	56 (14.8)	70 (18.5)	90 (23.8)	107 (28.3)	120 (31.7)	144 (38.0)	169 (44.7)
		@ 1500 min ⁻¹	42 (11.1)	52 (13.7)	68 (18.0)	81 (21.4)	90 (23.8)	108 (28.5)	127 (33.6)
		@ n_{max}	45,7 (61.2)	42,1 (56.4)	63 (84.4)	55,9 (74.9)	84 (112.6)	90,7 (121.5)	81,2 (108.8)
Max. power (theor.) ($\Delta p = p_{max}$ cont.)	kW (HP)	@ 2000 min ⁻¹	26,1 (35.0)	29 (38.9)	42 (56.3)	44,8 (60.0)	56 (75.0)	67,2 (90.0)	70,6 (94.6)
		@ 1500 min ⁻¹	19,6 (26.3)	21,8 (29.2)	31,5 (42.2)	33,6 (45.0)	42 (56.3)	50,4 (67.5)	52,9 (70.9)
		@ p_{max} cont.	124,8 (1105)	138,5 (1226)	200,5 (1775)	213,7 (1891)	267,4 (2367)	320,9 (2840)	337 (2983)
Max. torque (theor.)	Nm (lbf in)	@ 100 bar (1450 psi)	44,6 (395)	55,4 (490)	71,6 (634)	85,5 (757)	95,5 (845)	114,6 (1014)	134,8 (1193)
		Moment of inertia	kgm ² (ft ² lbs)	0,002 (0.05)	0,002 (0.05)	0,003 (0.07)	0,003 (0.07)	0,008 (0.19)	0,008 (0.19)
Fill volume	l (US gallons)	0,85 (0.22)	0,85 (0.22)	1 (0.26)	1 (0.26)	1,3 (0.34)	1,3 (0.34)	1,3 (0.34)	
Mass (approx.)	kg (lbs)	15 (33.1)	15 (33.1)	19 (41.9)	19 (41.9)	22 (48.5)	22 (48.5)	22 (48.5)	
Seals				N= Buna		V= Viton			
Operating temperature	°C (°F)	min.			-25 (-13)		-25 (-13)		
		max. cont.			80 (176)		110 (230)		
		max. peak			100 (212)		125 (257)		

03/06.2011

(1) = with an inlet pressure of 1 bar abs (14.5 psi).

Reducing the displacement or increasing the inlet pressure the max. speed change. See table at page 8.

For different working conditions, please consult our technical sales department.

TECHNICAL DATA

Technical data restrictions with fire resistant fluid

(1) = with an inlet pressure of 1 bar abs (14.5 psi).

HFA - Oil emulsion in water (5 ÷ 15 % of oil)

Pump type MVP			30-28	30-34	48-45	48-53	60-60	60-72	60-84
Max. outlet pressure p_{max}	bar (psi)	continuous	140 (2030)						
		intermittent	150 (2175)						
		peak	160 (2320)						
Max. speed n_{max}	min ⁻¹	@ V_{max} (1)	2200	1800	2000	1700	2000	1700	1500
Seals			N= Buna						
Operating temperature	°C (°F)	min.	2 (36)						
		max.	55 (131)						
Bearing life (ref. mineral oil)	%		20 %						

HFB - Water emulsion in oil (40 % of water)

Pump type MVP			30-28	30-34	48-45	48-53	60-60	60-72	60-84
Max. outlet pressure p_{max}	bar (psi)	continuous	160 (2320)						
		intermittent	170 (2465)						
		peak	180 (2610)						
Max. speed n_{max}	min ⁻¹	@ V_{max} (1)	2350	1900	2150	1800	2150	1800	1600
Seals			N= Buna						
Operating temperature	°C (°F)	min.	2 (36)						
		max.	60 (140)						
Bearing life (ref. mineral oil)	%		40 %						

HFC - Water-glycol (35 ÷ 55 % of water)

Pump type MVP			30-28	30-34	48-45	48-53	60-60	60-72	60-84
Max. outlet pressure p_{max}	bar (psi)	continuous	180 (2610)						
		intermittent	195 (2828)						
		peak	210 (3045)						
Max. speed n_{max}	min ⁻¹	@ V_{max} (1)	2350	1900	2150	1800	2150	1800	1600
Seals			N= Buna						
Operating temperature	°C (°F)	min.	-10 (14)						
		max.	60 (140)						
Bearing life (ref. mineral oil)	%		40 %						

03/06.2011

TECHNICAL DATA

Technical data restrictions with fire resistant fluid

(1) = with an inlet pressure of 1 bar abs (14.5 psi).

HFD - Phosphate ester										
Pump type MVP			30-28	30-34	48-45	48-53	60-60	60-72	60-84	
Max. outlet pressure p_{max}	bar (psi)	continuous								200 (2900)
		intermittent								220 (3190)
		peak								240 (3480)
Max. speed n_{max}	min^{-1}	@ V_{max} (1)	2350	1900	2150	1800	2150	1800	1600	
Seals									V= Viton	
Operating temperature	$^{\circ}C$ ($^{\circ}F$)	min.								-10 (14)
		max.								80 (176)
Bearing life (ref. mineral oil)	%									90 %

Technical data restrictions with biodegradable fluids

HETG - Natural based fluid (the water content must never exceed 0,1 %)										
Pump type MVP			30-28	30-34	48-45	48-53	60-60	60-72	60-84	
Max. outlet pressure p_{max}	bar (psi)	continuous								180 (2610)
		intermittent								195 (2828)
		peak								210 (3045)
Max. speed n_{max}	min^{-1}	@ V_{max} (1)	2350	1900	2150	1800	2150	1800	1600	
Seals									N= Buna	
Operating temperature	$^{\circ}C$ ($^{\circ}F$)	min.								-10 (14)
		max.								60 (140)
Bearing life (ref. mineral oil)	%									50 %

HEPG - Polyglycol based synthetic fluid (the water content must never exceed 0,1 %)										
Pump type MVP			30-28	30-34	48-45	48-53	60-60	60-72	60-84	
Max. outlet pressure p_{max}	bar (psi)	continuous								180 (2610)
		intermittent								195 (2828)
		peak								210 (3045)
Max. speed n_{max}	min^{-1}	@ V_{max} (1)	2350	1900	2150	1800	2150	1800	1600	
Seals									V= Viton	
Operating temperature	$^{\circ}C$ ($^{\circ}F$)	min.								-15 (5)
		max.								90 (194)
Bearing life (ref. mineral oil)	%									75 %

HEES - Synthetic esters (the water content must never exceed 0,1 %)										
Pump type MVP			30-28	30-34	48-45	48-53	60-60	60-72	60-84	
Seals									V= Viton	
Operating temperature	$^{\circ}C$ ($^{\circ}F$)	min.								-15 (5)
		max.								80 (176)
Bearing life (ref. mineral oil)	%									100 %

03/06.2011

TECHNICAL DATA

Design calculations for pump

Q	l/min (US gpm)	Flow
M	Nm (lbf in)	Torque
P	kW (HP)	Power
V	cm ³ /rev (in ³ /rev)	Displacement
n	min ⁻¹	Speed
Δp	bar (psi)	Pressure
$\eta_v = \eta_v(V, \Delta p, n)$		Volumetric efficiency
$\eta_{hm} = \eta_{hm}(V, \Delta p, n)$		Hydro-mechanical efficiency
$\eta_t = \eta_v \cdot \eta_{hm}$		Overall efficiency

$$Q = Q_{theor.} \cdot \eta_v$$

$$Q_{theor.} = \frac{V \text{ (cm}^3\text{/rev)} \cdot n \text{ (min}^{-1}\text{)}}{1000} \quad [\text{l/min}]$$

$$M = \frac{M_{theor.}}{\eta_{hm}}$$

$$M_{theor.} = \frac{\Delta p \text{ (bar)} \cdot V \text{ (cm}^3\text{/rev)}}{62,83} \quad [\text{Nm}]$$

$$P_{in} = \frac{P_{out}}{\eta_t}$$

$$P_{out} = \frac{\Delta p \text{ (bar)} \cdot Q \text{ (l/min)}}{600} \quad [\text{kW}]$$

Max. permissible load on drive shaft

Pump type		MVP 30•28	MVP 30•34	MVP 48•45	MVP 48•53	MVP 60•60	MVP 60•72	MVP 60•84
F_{ax} Axial force	N (lbf)	1000 (225)	1000 (225)	1500 (337)	1500 (337)	2000 (450)	2000 (450)	2000 (450)
F_{rad} Radial force	N (lbf) @ L/2	1500 (337)	1500 (337)	1500 (337)	1500 (337)	3000 (675)	3000 (675)	3000 (675)

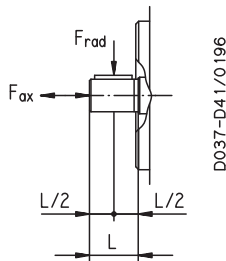

% Variation of the max. speed in relation of the inlet pressure and/or displacement reduction

Inlet pressure	Displacement %					% Variation of the max. speed
	65	70	80	90	100	
psi (bar abs)						
12 (0,8)	120	115	105	97	90	03/06.2011
13 (0,9)	120	120	110	103	95	
14.5 (1,0)	120	120	115	107	100	
17 (1,2)	120	120	120	113	106	
20 (1,4)	120	120	120	120	112	
23 (1,6)	120	120	120	120	117	
29 (2,0)	120	120	120	120	120	

Example 1

Displacement: 100 %
Speed: 100 %
Inlet pressure: 1,0 bar abs. (14.5 psi)

Example 2

Displacement: 80 %
Inlet pressure: 1,0 bar abs. (14.5 psi)
Speed: 115 %

PORTS POSITION

Anti-clock rotation

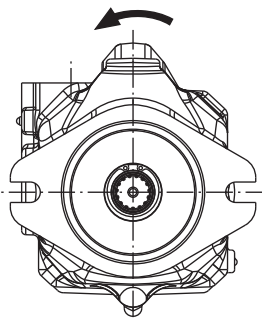

Side ports

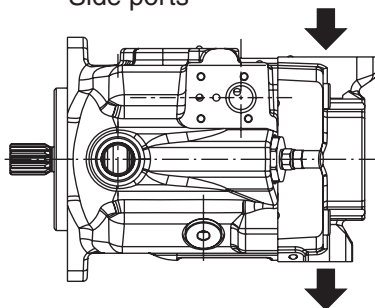

Rear ports

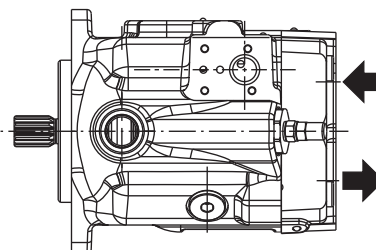

Clockwise rotation

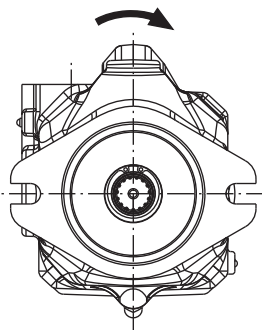

Side ports

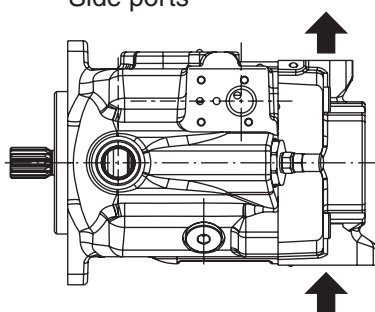

Rear ports

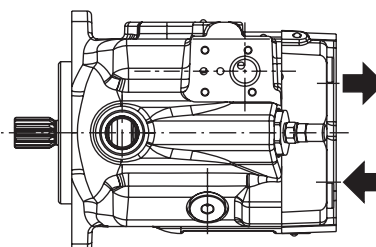

DISPLACEMENT SETTING

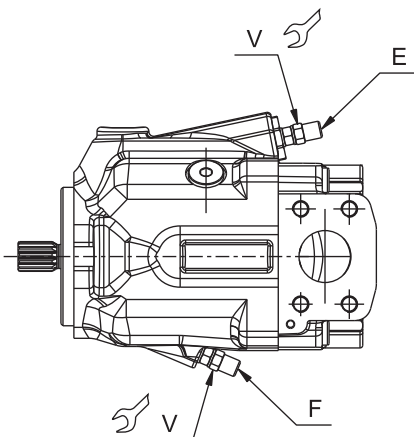

- E:** Max. displacement limiter
- F:** Min. displacement limiter
- G:** Min. and Max. displacement limiter (standard)
- V:** Tightening torque $10^{\pm 1}$ Nm (80 ÷ 97 lbf in)

03/06.2011

			MVP 30	MVP 48	MVP 60
Max. displacement setting range	cm ³ /rev (in ³ /rev)	from	17,4 (1.06)	34,9 (2.13)	55 (3.36)
		to	34,8 (2.12)	53,7 (3.28)	84,7 (5.17)
Min. displacement setting range	cm ³ /rev (in ³ /rev)	from	0	0	0
		to	17,4 (1.06)	10,7 (0.65)	38,1 (2.32)
One turn of screw changes pump displacement by approximately	cm ³ /rev (in ³ /rev)	E	2,8 (0.17)	3,2 (0.20)	5,0 (0.31)
		F	2,3 (0.14)	3,0 (0.18)	4,2 (0.26)

For different setting ranges, please consult our technical sales department.

MVP30•28

OPERATING CURVES

Each curve has been obtained at 50 °C (122 °F), using oil with viscosity 46 cSt (210 SSU) at 40 °C (104 °F) and at these speed: (1) 1500 min⁻¹, (2) 2000 min⁻¹, (3) 3500 min⁻¹

Delivery / power

@ max. displacement

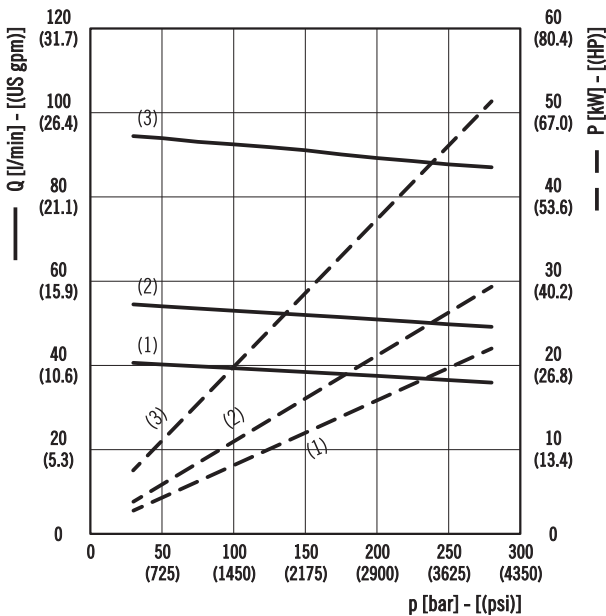

Noise level

Distance from microphone to pump = 1 m (39.37 in)

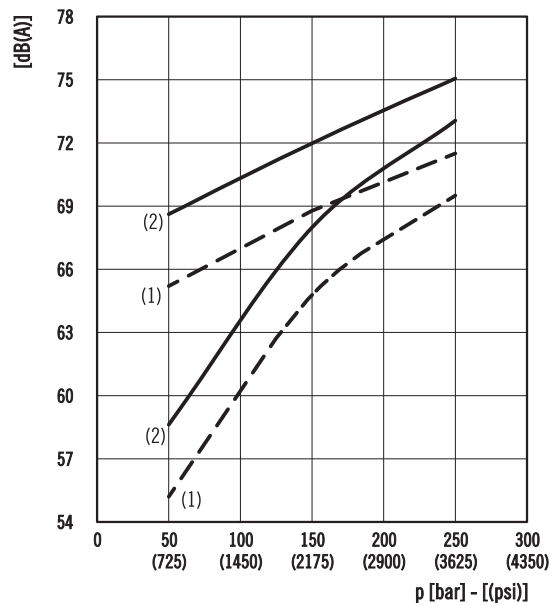

Volumetric efficiency

@ max. displacement

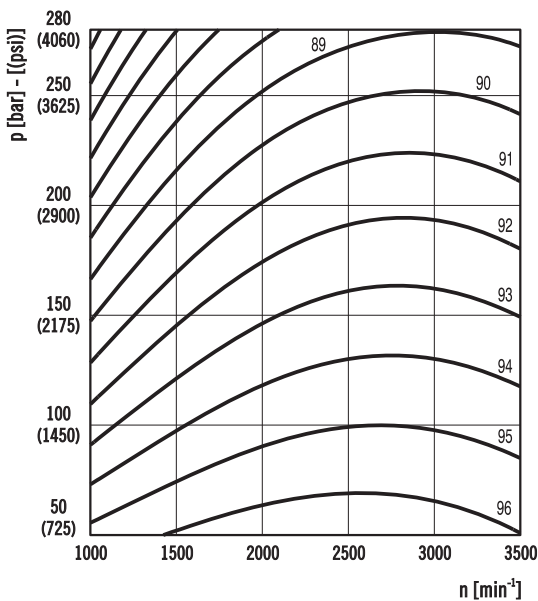

Overall efficiency

@ max. displacement

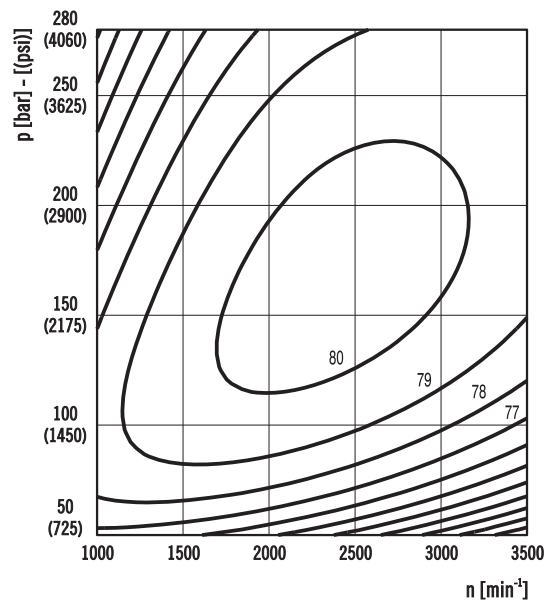

03/06.2011

Values shown in the diagrams are indicative only. Actual values may vary depending on the pump configuration.

MVP30•34

OPERATING CURVES

Each curve has been obtained at 50 °C (122 °F), using oil with viscosity 46 cSt (210 SSU) at 40 °C (104 °F) and at these speed: (1) 1500 min⁻¹, (2) 2000 min⁻¹, (3) 2900 min⁻¹

Delivery / power

@ max. displacement

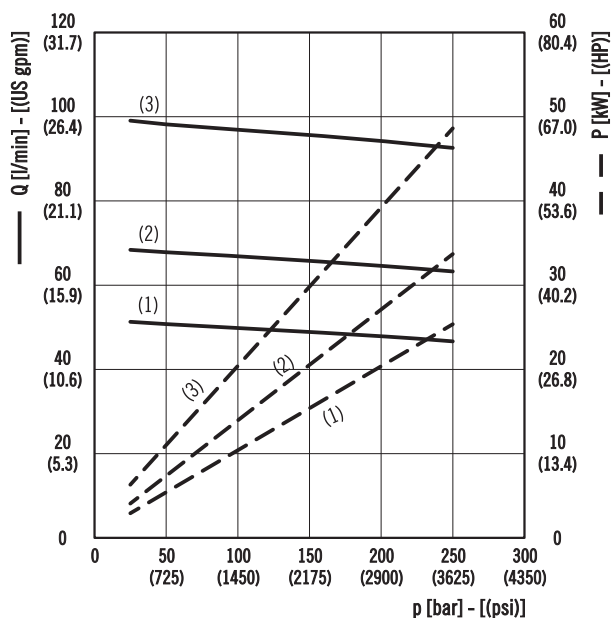

Noise level

Distance from microphone to pump = 1 m (39.37 in)

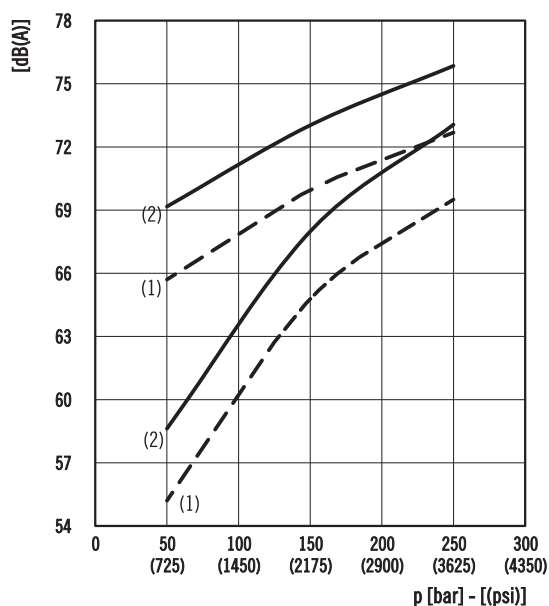

Volumetric efficiency

@ max. displacement

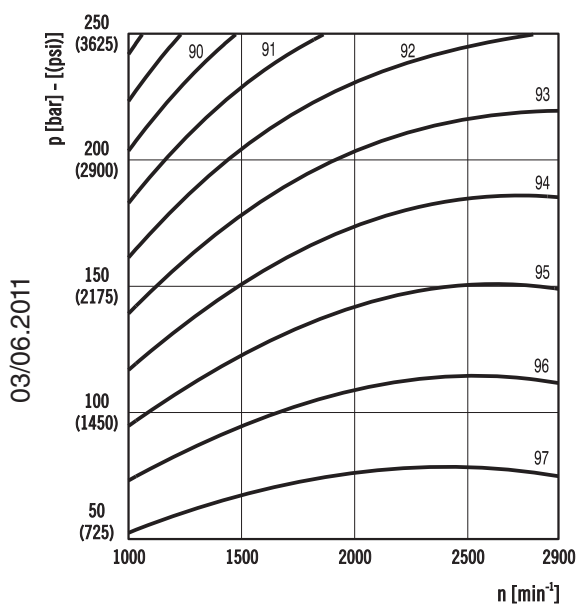

Overall efficiency

@ max. displacement

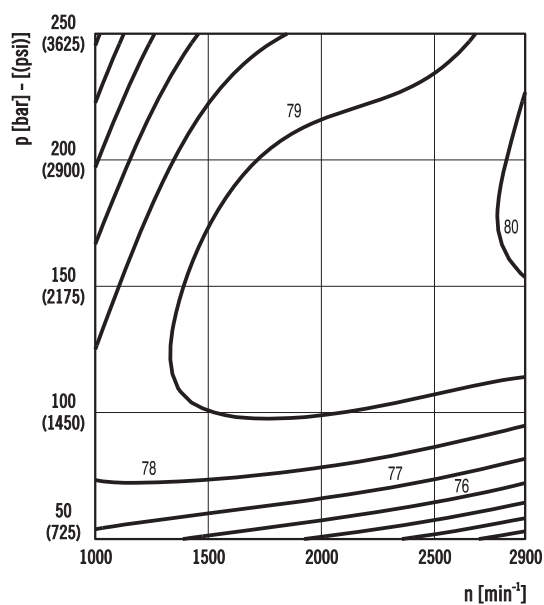

03/06.2011

Values shown in the diagrams are indicative only. Actual values may vary depending on the pump configuration.

MVP48•45

OPERATING CURVES

Each curve has been obtained at 50 °C (122 °F), using oil with viscosity 46 cSt (210 SSU) at 40 °C (104 °F) and at these speed: (1) 1500 min⁻¹, (2) 2000 min⁻¹, (3) 3000 min⁻¹

Delivery / power

@ max. displacement

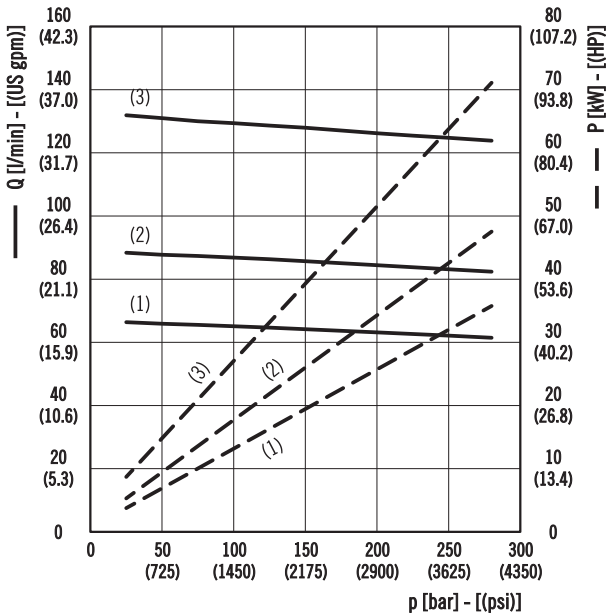

Noise level

Distance from microphone to pump = 1 m (39.37 in)

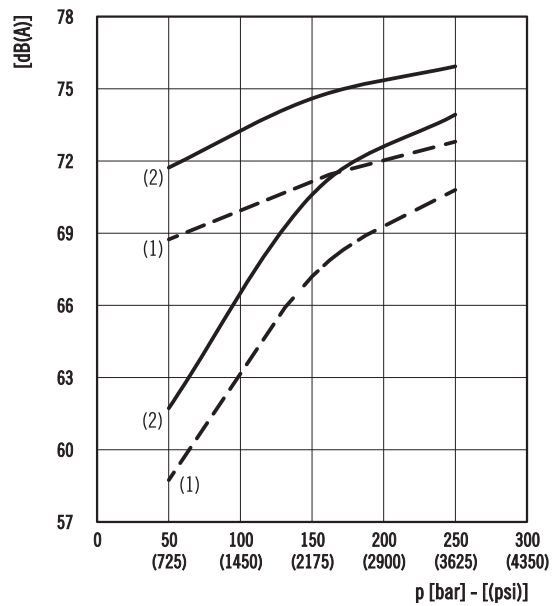

Volumetric efficiency

@ max. displacement

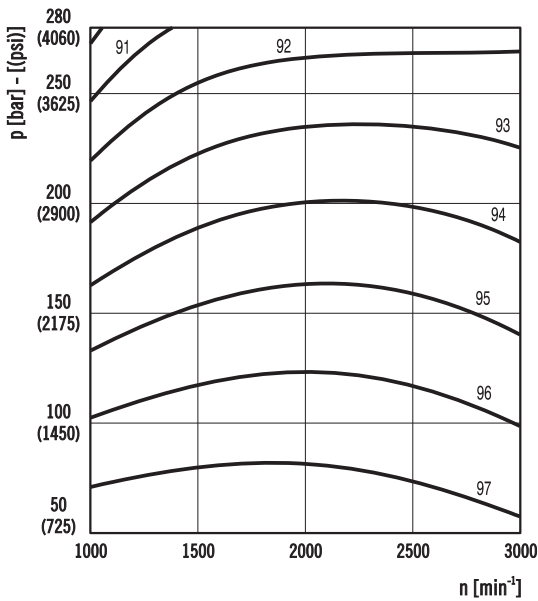

Overall efficiency

@ max. displacement

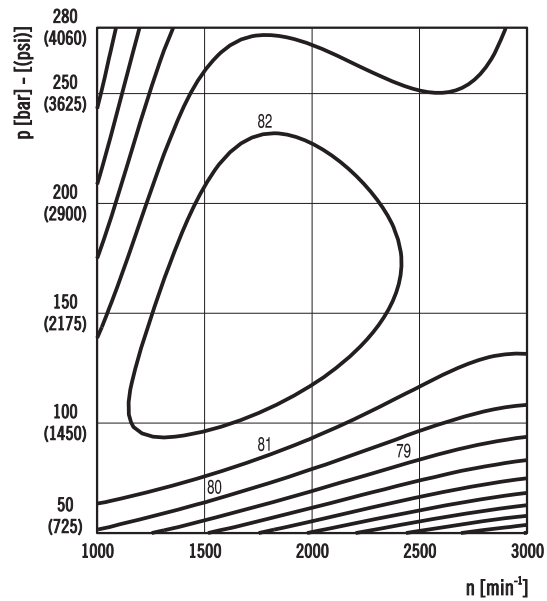

03/06.2011

Values shown in the diagrams are indicative only. Actual values may vary depending on the pump configuration.

MVP48•53

OPERATING CURVES

Each curve has been obtained at 50 °C (122 °F), using oil with viscosity 46 cSt (210 SSU) at 40 °C (104 °F) and at these speed: (1) 1500 min⁻¹, (2) 2000 min⁻¹, (3) 2500 min⁻¹

Delivery / power

@ max. displacement

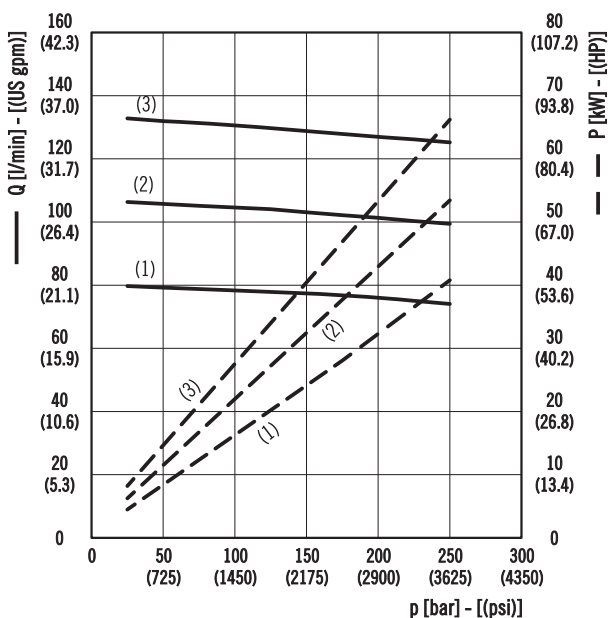

Noise level

Distance from microphone to pump = 1 m (39.37 in)

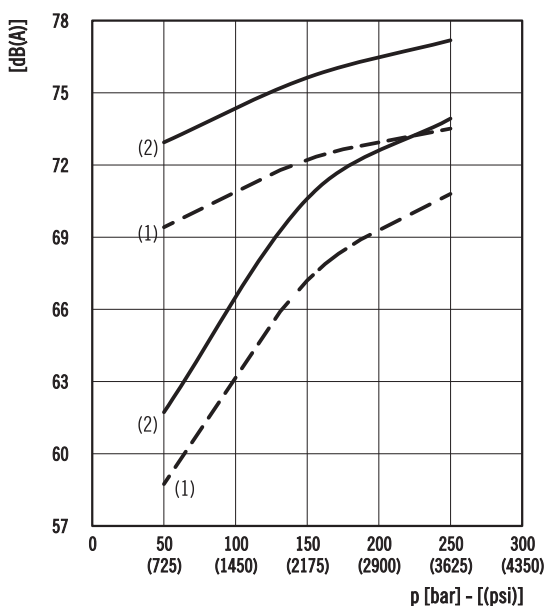

Volumetric efficiency

@ max. displacement

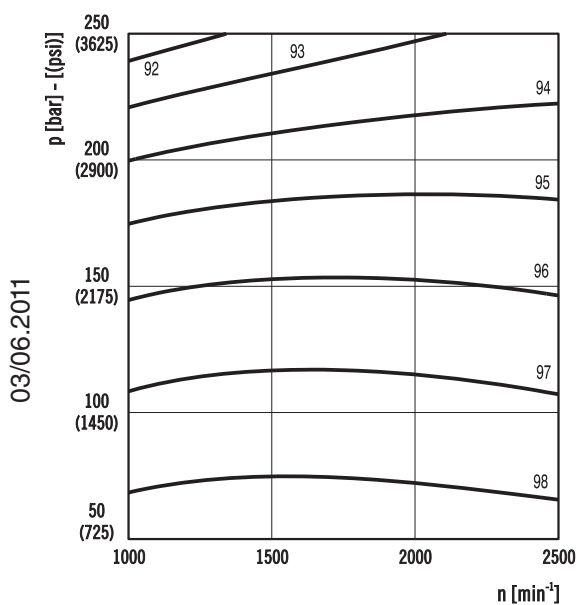

Overall efficiency

@ max. displacement

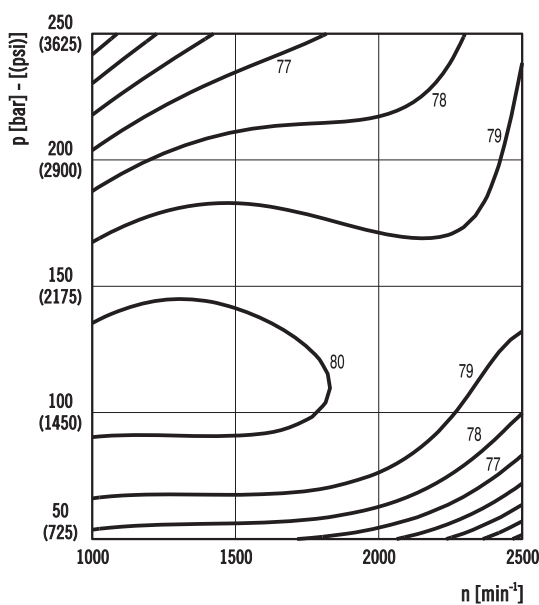

Values shown in the diagrams are indicative only. Actual values may vary depending on the pump configuration.

MVP60•60

OPERATING CURVES

Each curve has been obtained at 50 °C (122 °F), using oil with viscosity 46 cSt (210 SSU) at 40 °C (104 °F) and at these speed: (1) 1500 min⁻¹, (2) 2000 min⁻¹, (3) 3000 min⁻¹

Delivery / power

@ max. displacement

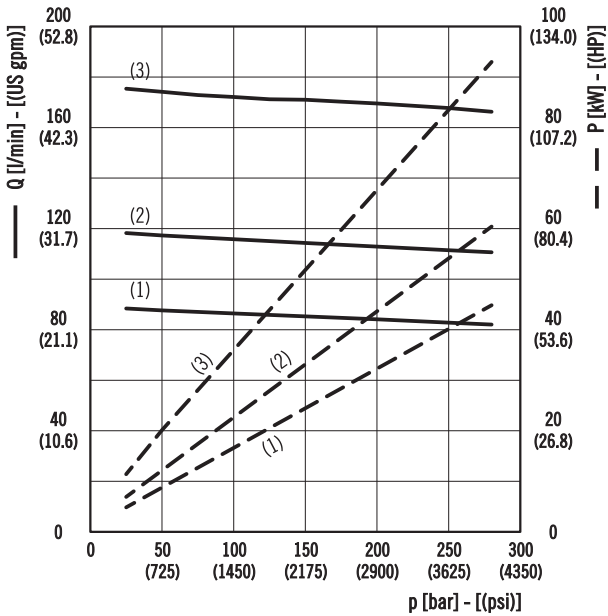

Noise level

Distance from microphone to pump = 1 m (39.37 in)

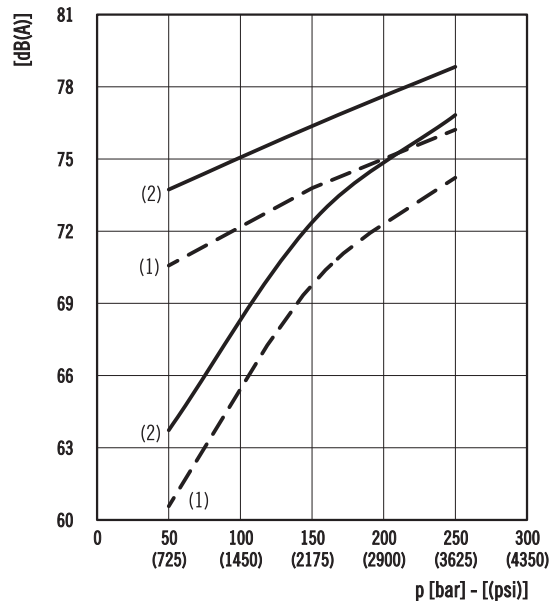

Volumetric efficiency

@ max. displacement

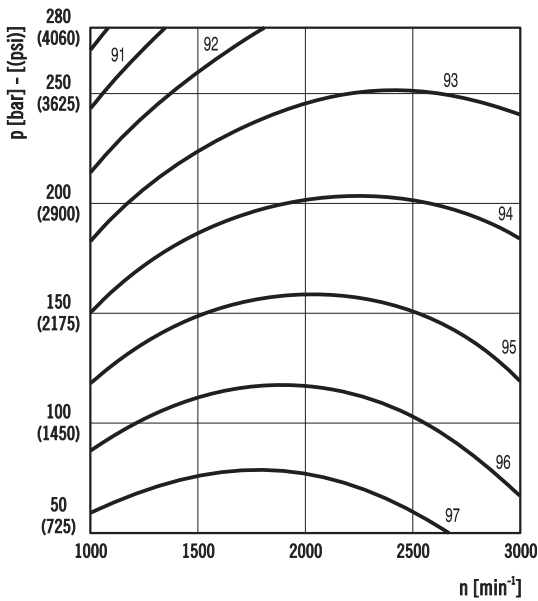

Overall efficiency

@ max. displacement

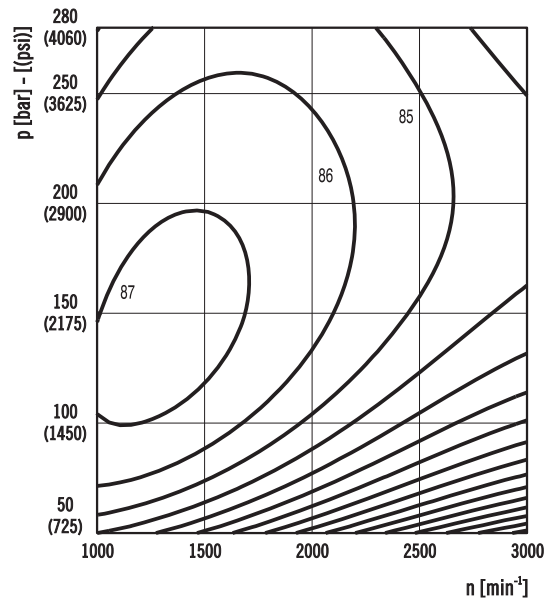

03/06.2011

Values shown in the diagrams are indicative only. Actual values may vary depending on the pump configuration.

MVP60•72

OPERATING CURVES

Each curve has been obtained at 50 °C (122 °F), using oil with viscosity 46 cSt (210 SSU) at 40 °C (104 °F) and at these speed: (1) 1500 min⁻¹, (2) 2000 min⁻¹, (3) 2700 min⁻¹

Delivery / power

@ max. displacement

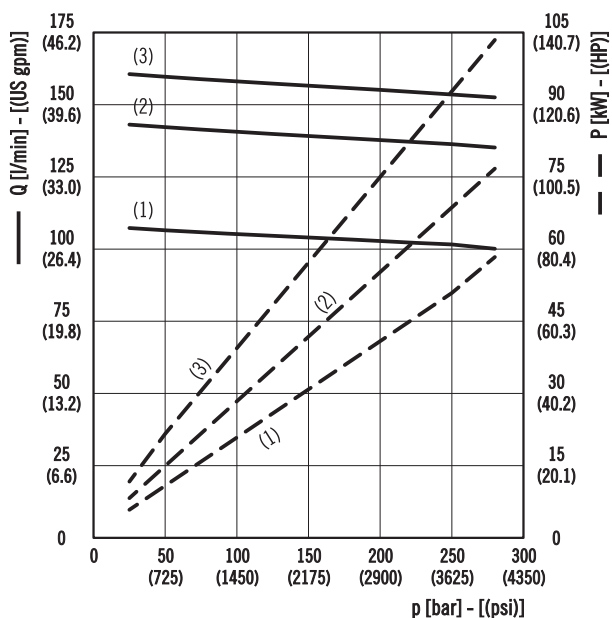

Noise level

Distance from microphone to pump = 1 m (39.37 in)

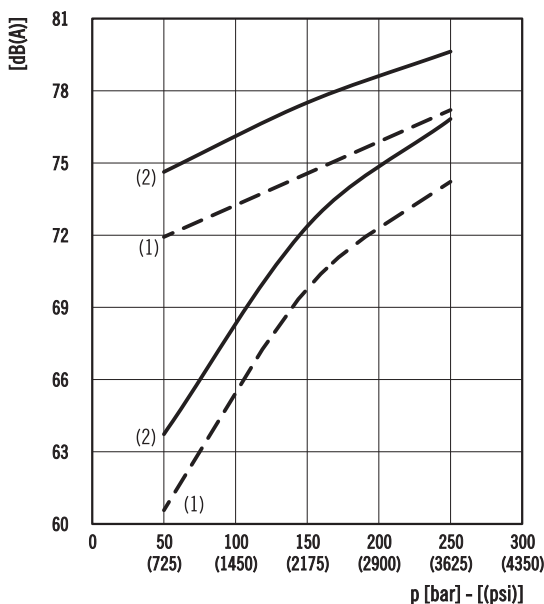

Volumetric efficiency

@ max. displacement

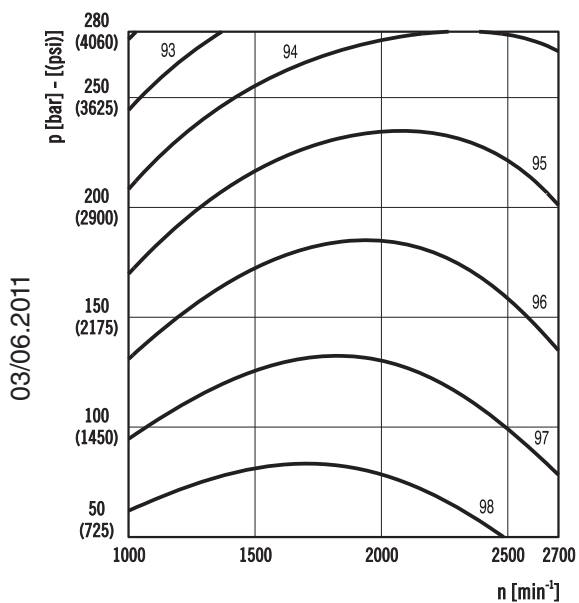

Overall efficiency

@ max. displacement

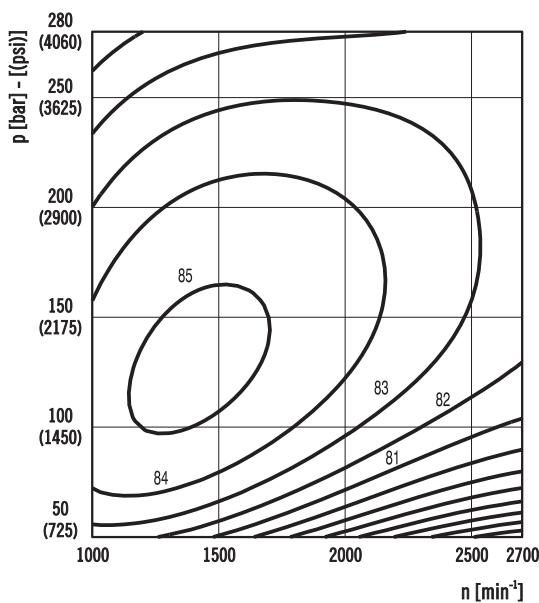

Values shown in the diagrams are indicative only. Actual values may vary depending on the pump configuration.

MVP60•84

OPERATING CURVES

Each curve has been obtained at 50 °C (122 °F), using oil with viscosity 46 cSt (210 SSU) at 40 °C (104 °F) and at these speed: (1) 1500 min⁻¹, (2) 2000 min⁻¹, (3) 2300 min⁻¹

Delivery / power

@ max. displacement

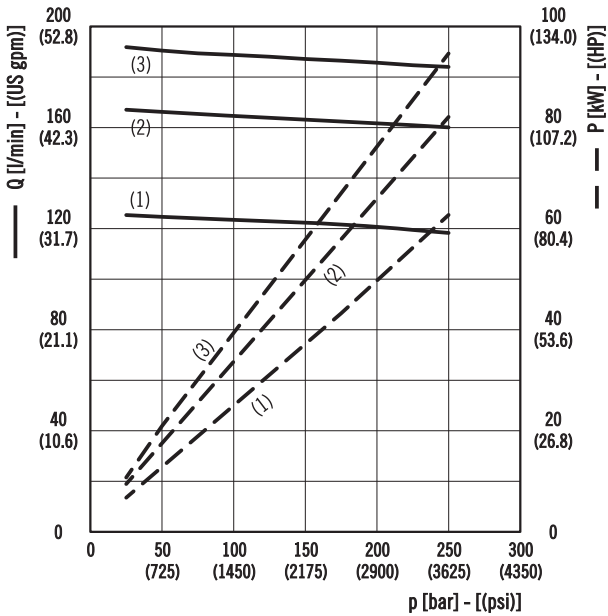

Noise level

Distance from microphone to pump = 1 m (39.37 in)

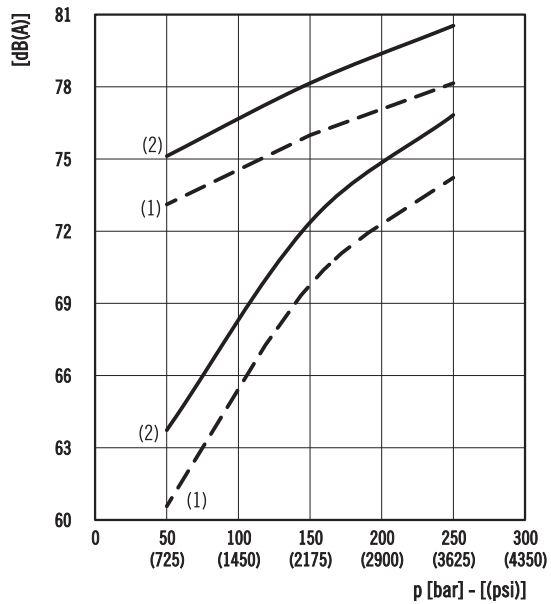

Volumetric efficiency

@ max. displacement

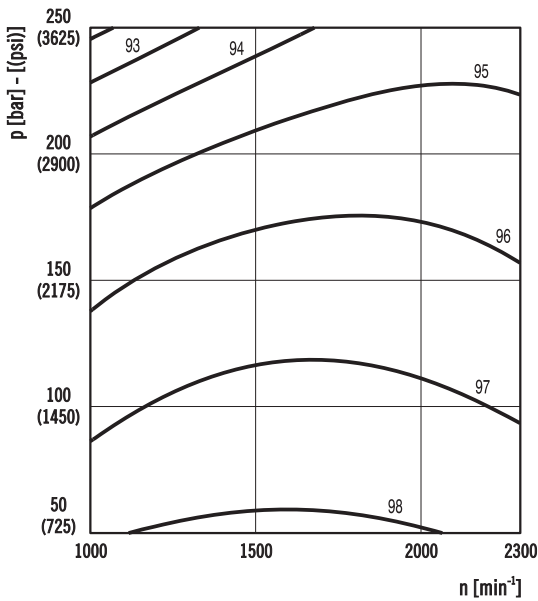

Overall efficiency

@ max. displacement

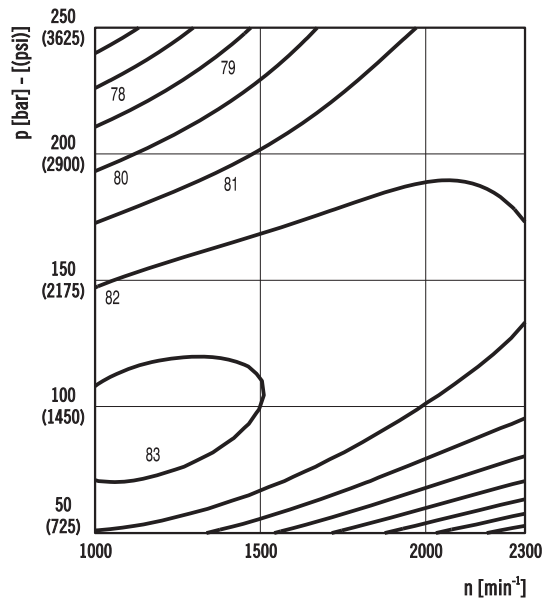

03/06.2011

Values shown in the diagrams are indicative only. Actual values may vary depending on the pump configuration.

MVP30

SIDE PORTS - DIMENSIONS

L

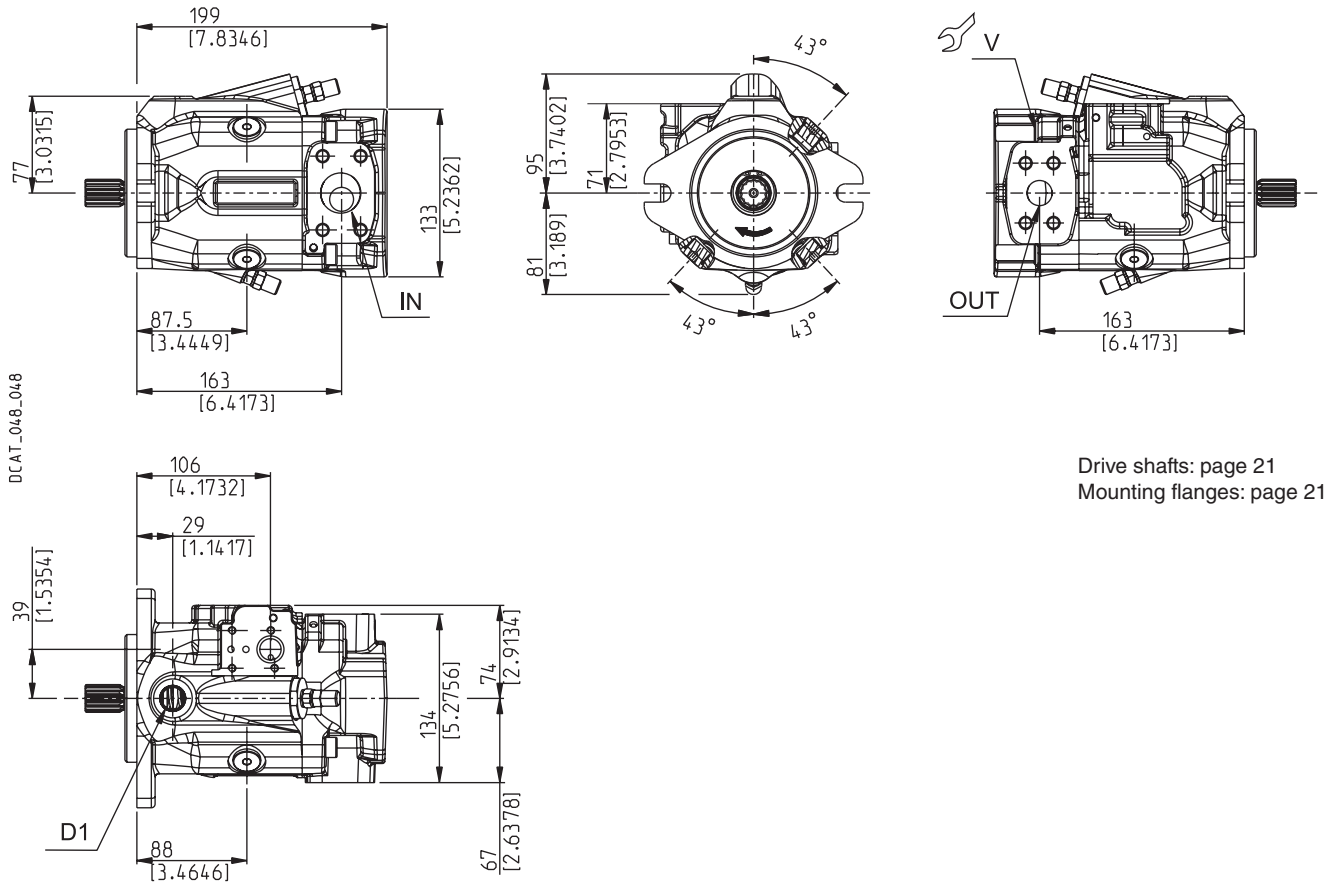

03/06.2011

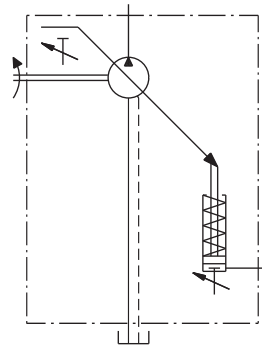

Screws tightening torque Nm (lbf in)

V
70 ±7 (558 ÷ 682)

Ports (Nominal size)

IN	OUT	D1
1" 1/4	3/4"	Drain port

Dimensions at page 32

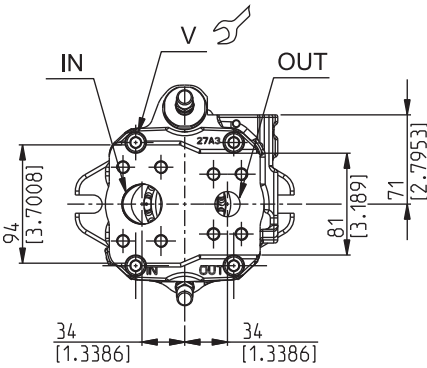

DCAT_048_047

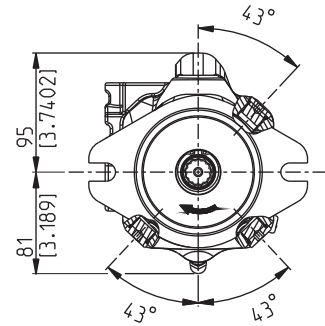
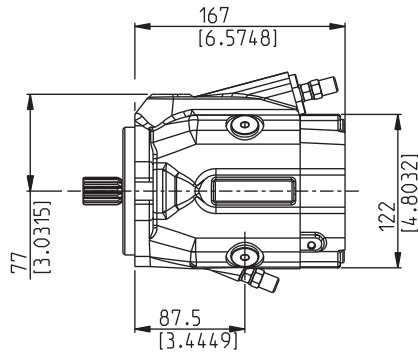

Drive shafts: page 21
Mounting flanges: page 21

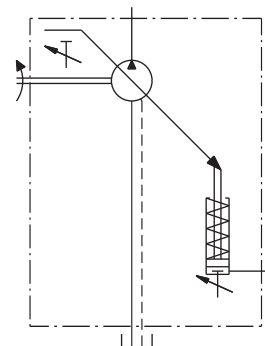
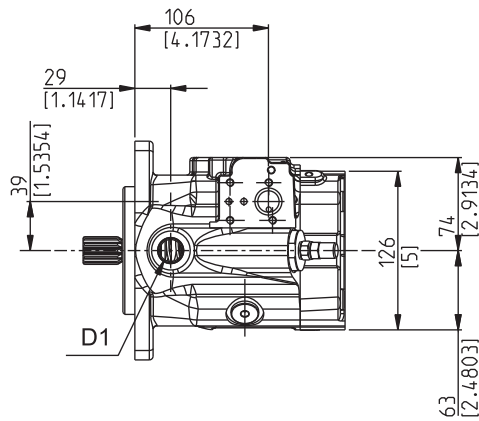
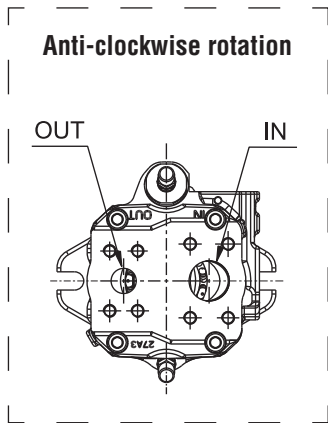

Screws tightening torque Nm (lbf in)

V
70 ^{±7} (558 ÷ 682)

Ports (Nominal size)

IN	OUT	D1
1" 1/4	3/4"	Drain port

Dimensions at page 32

MVP30/KP20

MULTIPLE PUMPS - DIMENSIONS

L

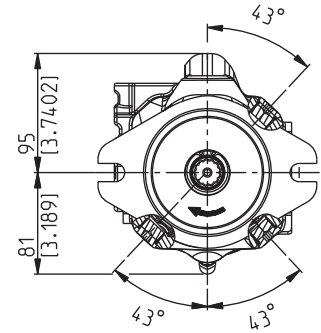
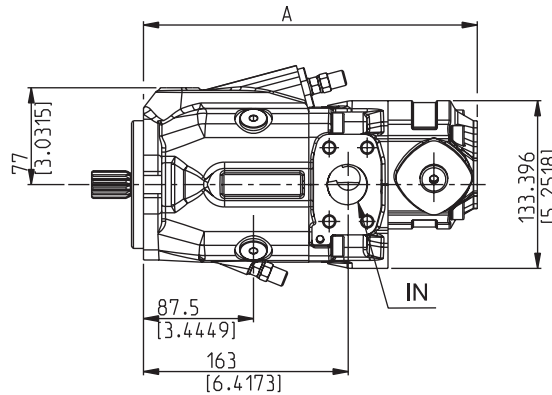
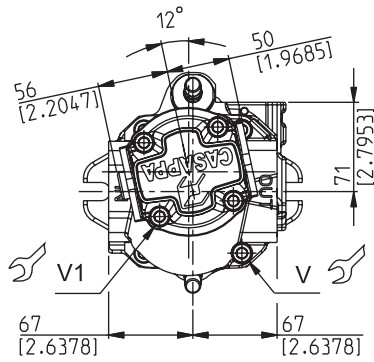

DCAT_048_048_KP20

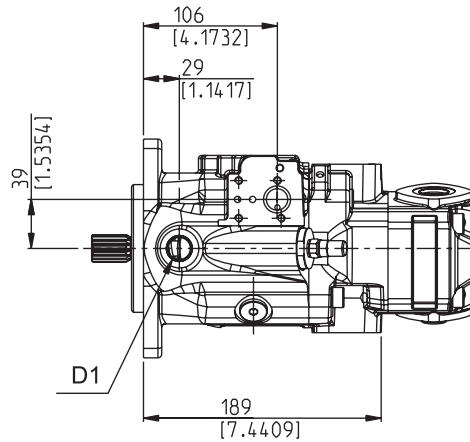

Drive shafts: page 21
Mounting flanges: page 21

Screws tightening torque Nm (lbf in)

V	V1
70 ±7 (558 ÷ 682)	70 ±7 (558 ÷ 682)

Ports (Nominal size)

IN	OUT	D1
MVP	MVP	KP20
1" 1/4	3/4"	1/2"
		Drain port

03/06.2011

Dimensions at page 32

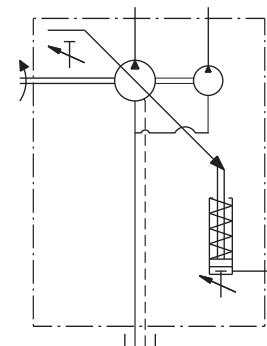
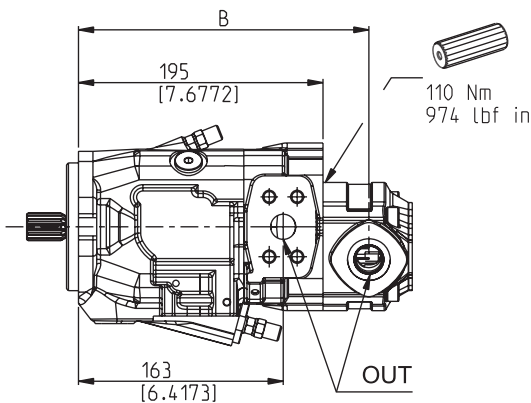

Gear pump KAPPA

Pump type	Mounting flange	20•4	20•6,3	20•8	20•11,2	20•14	20•16	20•20	Dimensions
MVP30	S5	246,5 (9.7047)	249 (9.8031)	251,5 (9.9016)	255 (10.0394)	259 (10.1969)	264,5 (10.4134)	271 (10.6693)	mm (in) A
		219 (8.6220)	221,5 (8.7205)	224 (8.8189)	227,5 (8.9567)	226 (8.8976)	231,5 (9.1142)	238 (9.3701)	mm (in) B

MVP30/PHP20

MULTIPLE PUMPS - DIMENSIONS

L

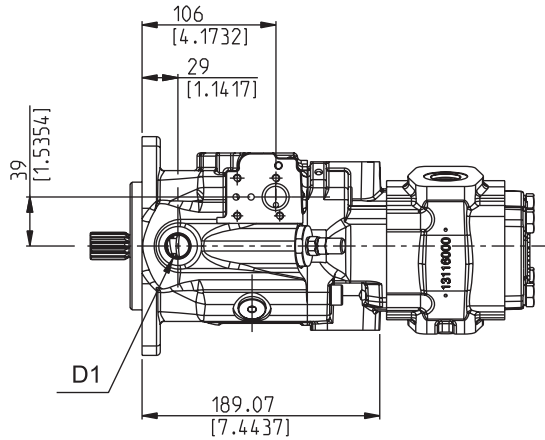
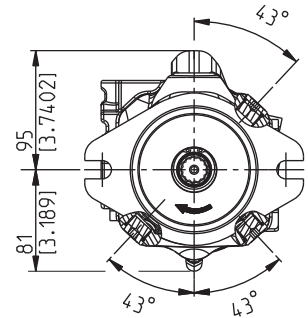
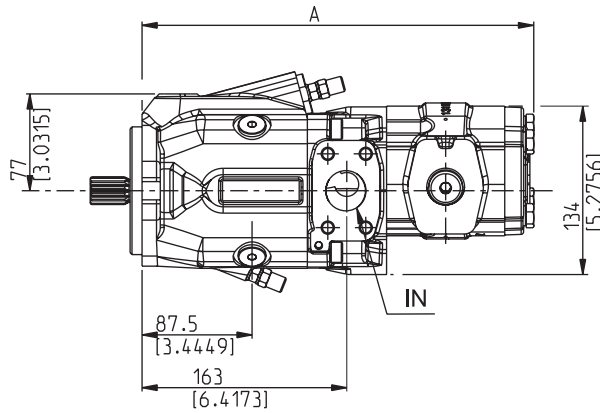
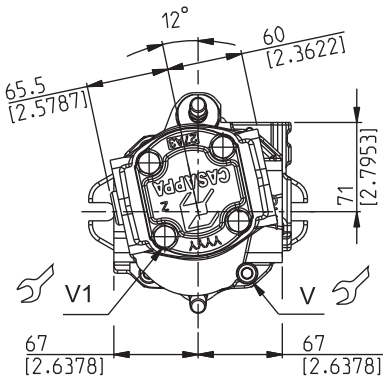

Drive shafts: page 21
Mounting flanges: page 21

Also available in combination with PLP20

Screws tightening torque Nm (lbf in)

V	V1
70 ±7 (558 ÷ 682)	70 ±7 (558 ÷ 682)

Ports (Nominal size)

IN	OUT	D1
MVP	MVP	PHP20
1" 1/4	3/4"	1/2"
		Drain port

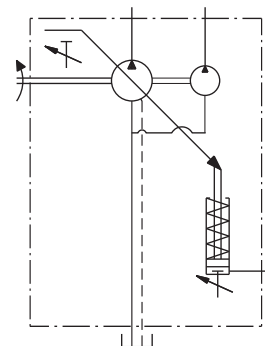
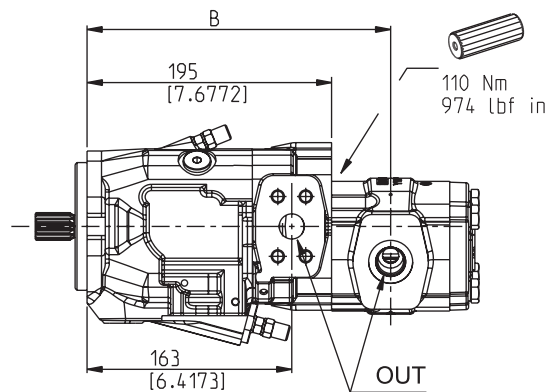

Dimensions at page 32

Gear pump POLARIS PH

Pump type	Mounting flange	20•19	20•20	20•23	20•24,5	20•25	20•27,8	20•31,5	Dimensions
MVP30	S5	291,5 (11.4764)	294,6 (11.5984)	297,9 (11.7283)	300,2 (11.8189)	302,6 (11.9134)	305,3 (12.0197)	312,6 (12.3071)	mm (in) A
		231,45 (9.1122)	233 (9.1732)	234,65 (9.2382)	235,8 (9.2835)	237 (9.3307)	238,35 (9.3839)	242 (9.5276)	mm (in) B

03/06.2011

MVP30

DRIVE SHAFTS / MOUNTING FLANGES

SAE "B" SPLINE

04

Mounting face refers to flange code **S5**

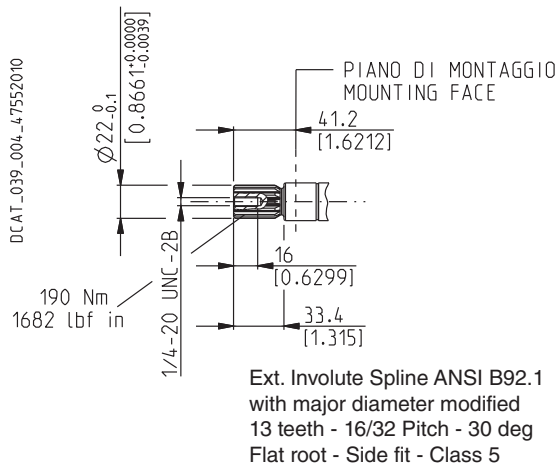

SAE "B" 2 HOLES

S5

Conforms to SAE J744

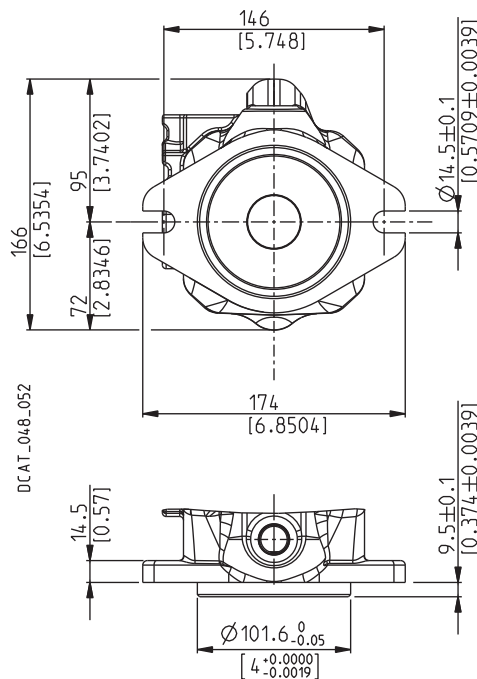

03/06.2011

MVP48

SIDE PORTS - DIMENSIONS

L

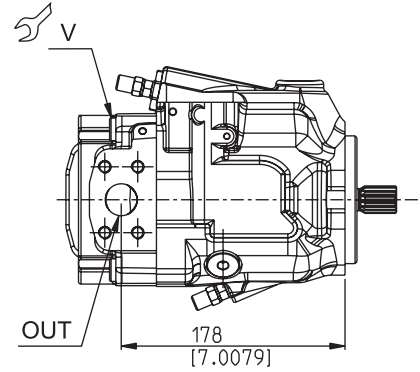
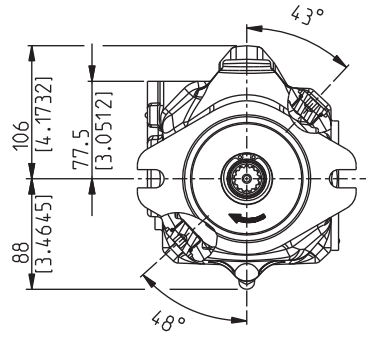
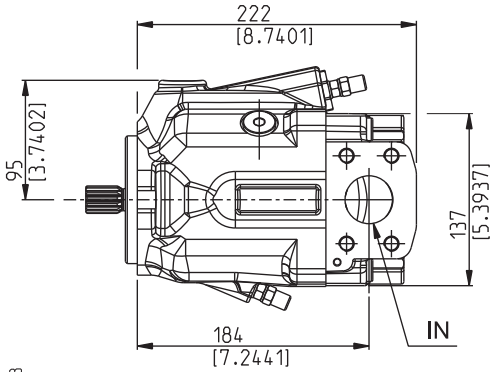

DCAT_048_053

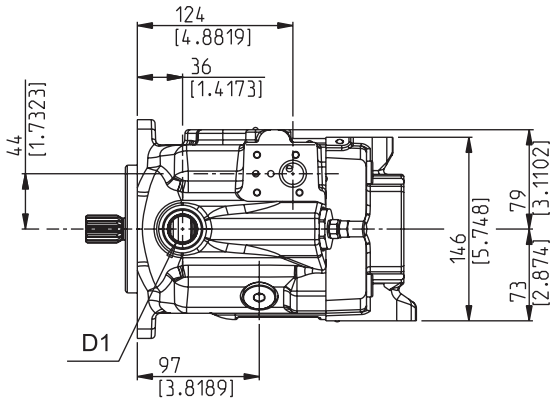

Drive shafts: page 26
Mounting flanges: page 26

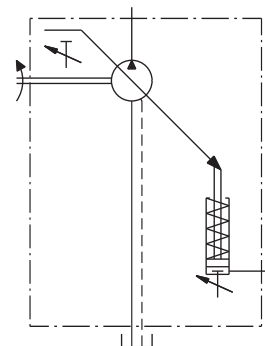

03/06.2011

Screws tightening torque Nm (lbf in)

V
100 ±10 (797 ÷ 974)

Ports (Nominal size)

IN	OUT	D1
1" 1/2	1"	Drain port

Dimensions at page 32

MVP48

REAR PORTS - DIMENSIONS

P

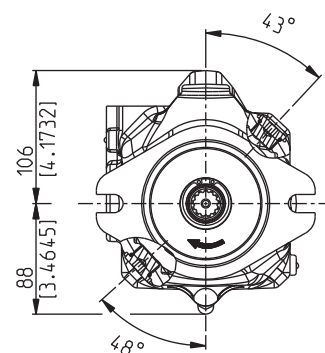
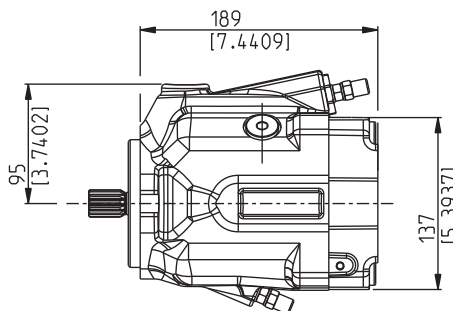
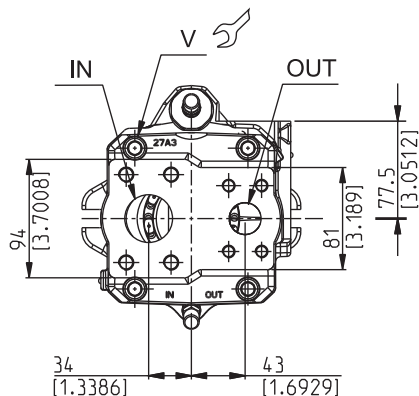

DCAT_048_031

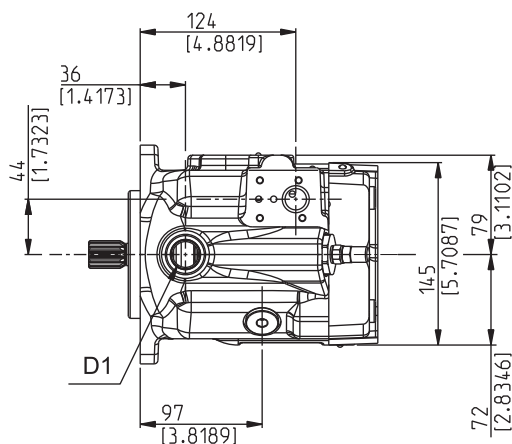
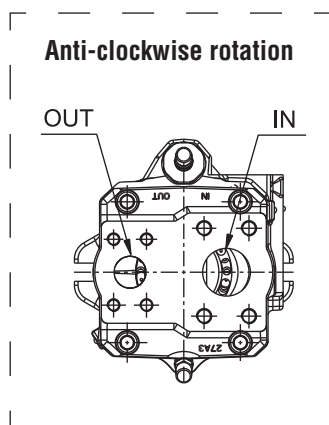

Drive shafts: page 26
Mounting flanges: page 26

03/06.2011

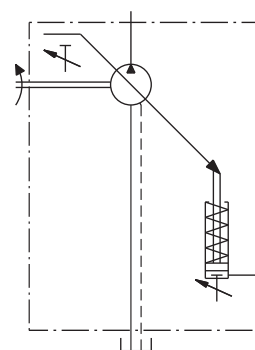

Screws tightening torque Nm (lbf in)

V
100 ±10 (797 ÷ 974)

Ports (Nominal size)

IN	OUT	D1
1" 1/2	1"	Drain port

Dimensions at page 32

MVP48/KP20

MULTIPLE PUMPS - DIMENSIONS

L

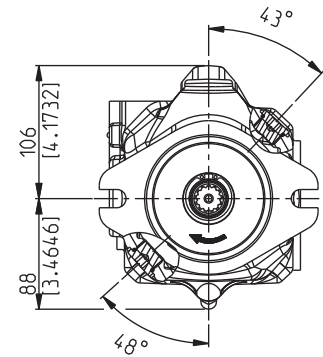
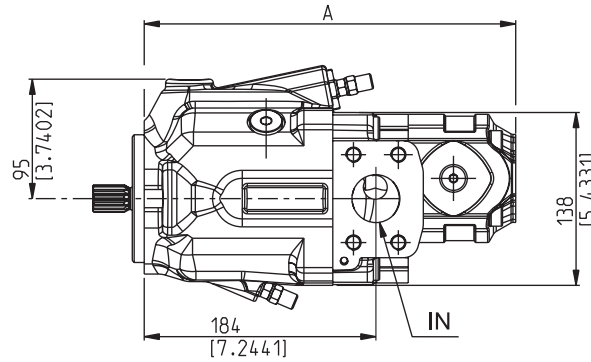
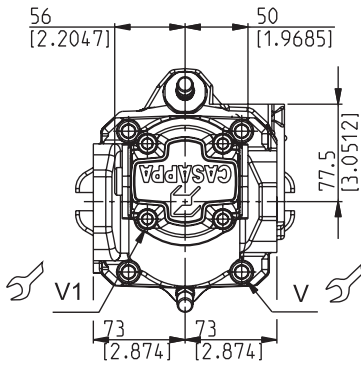

DCAT_048_031_KP20

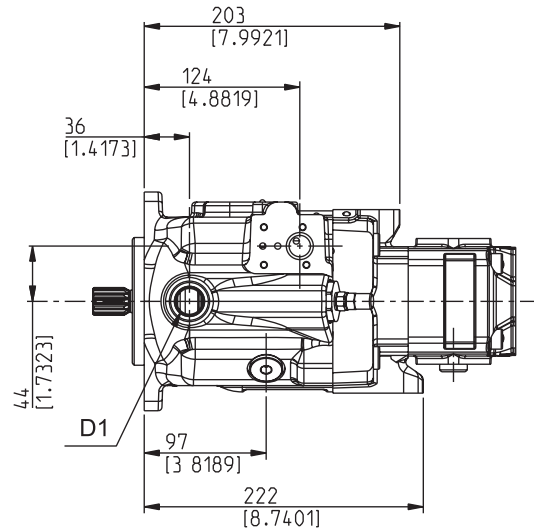

Drive shafts: page 26
Mounting flanges: page 26

Screws tightening torque Nm (lbf in)

V	V1
100 ±10 (797 ÷ 974)	70 ±7 (558 ÷ 682)

Ports (Nominal size)

IN	OUT	D1
MVP	MVP	KP20
1" 1/2	1"	1/2"
		Drain port

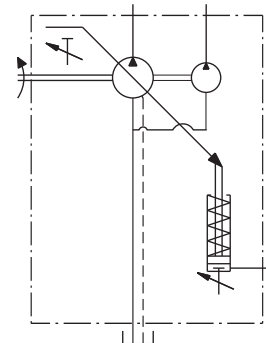
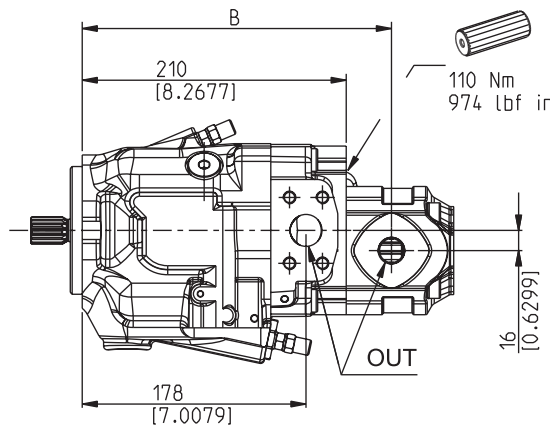

Dimensions at page 32

03/06.2011

Gear pump KAPPA

Pump type	Mounting flange	20•4	20•6,3	20•8	20•11,2	20•14	20•16	20•20	Dimensions
MVP48	S5	261,5 (10.2953)	264 (10.3937)	266,5 (10.4921)	270 (10.6299)	274 (10.7874)	279,5 (11.0039)	286 (11.2598)	mm (in) A
		234 (9.2126)	236,5 (9.3110)	239 (9.4094)	242,5 (9.5472)	241 (9.4882)	246,5 (9.7047)	253 (9.9606)	mm (in) B

MVP48/PHP20

MULTIPLE PUMPS - DIMENSIONS

L

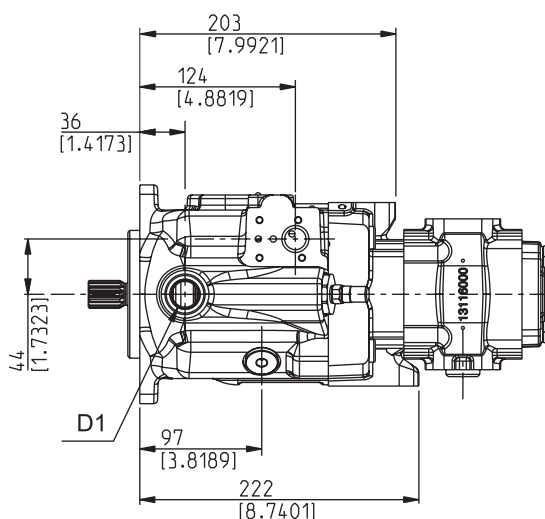
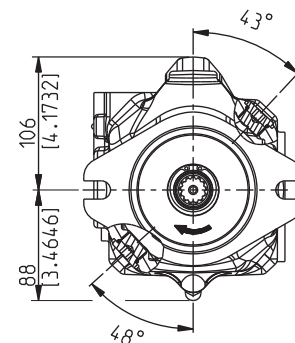
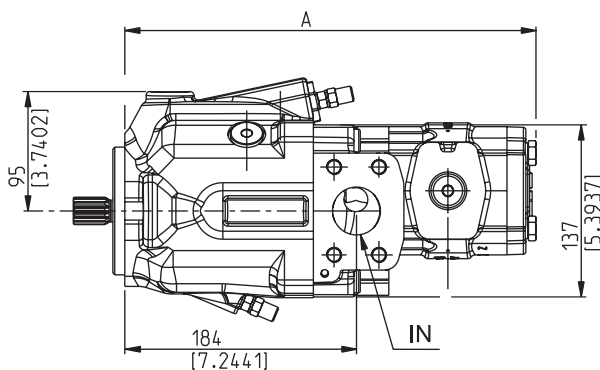
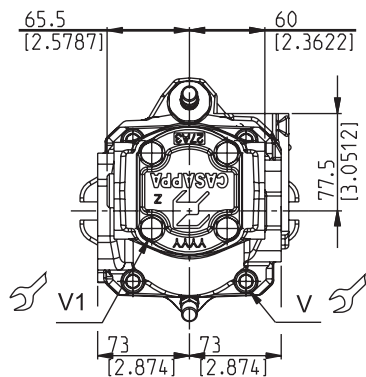

Drive shafts: page 26
Mounting flanges: page 26

Also available in combination with PLP20

Screws tightening torque Nm (lbf in)

V	V1
100 ±10 (797 ÷ 974)	70 ±7 (558 ÷ 682)

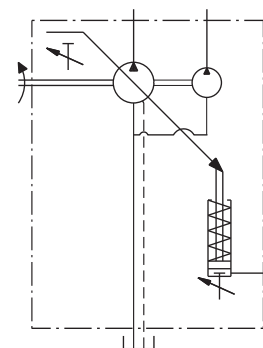
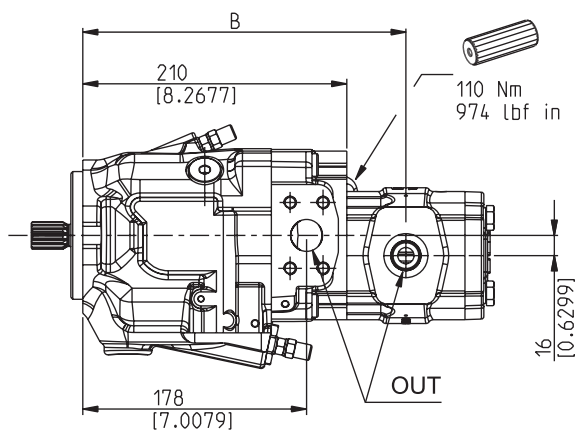

Ports (Nominal size)

IN	OUT	D1
MVP	MVP	PHP20
1" 1/2	1"	1/2"
		Drain port

03/06.2011

Dimensions at page 32

Gear pump POLARIS PH

Pump type	Mounting flange	20•19	20•20	20•23	20•24,5	20•25	20•27,8	20•31,5	Dimensions
MVP48	S5	306,5 (12.0669)	309,6 (12.1890)	312,9 (12.3189)	315,2 (12.4094)	317,6 (12.5039)	320,3 (12.6102)	327,6 (12.8976)	mm (in) A
		246,45 (9.7028)	248 (9.7638)	249,65 (9.8287)	250,8 (9.8740)	252 (9.9213)	253,35 (9.9744)	257 (10.1181)	mm (in) B

MVP48

DRIVE SHAFTS / MOUNTING FLANGES

SAE "B" SPLINE

04

Mounting face refers to flange code **S5**

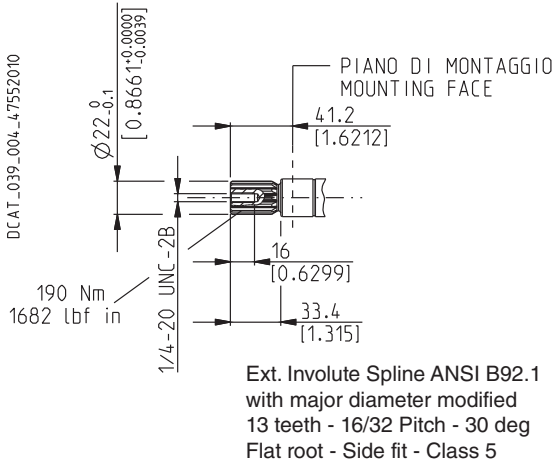

SAE "B" 2 HOLES

S5

Conforms to SAE J744

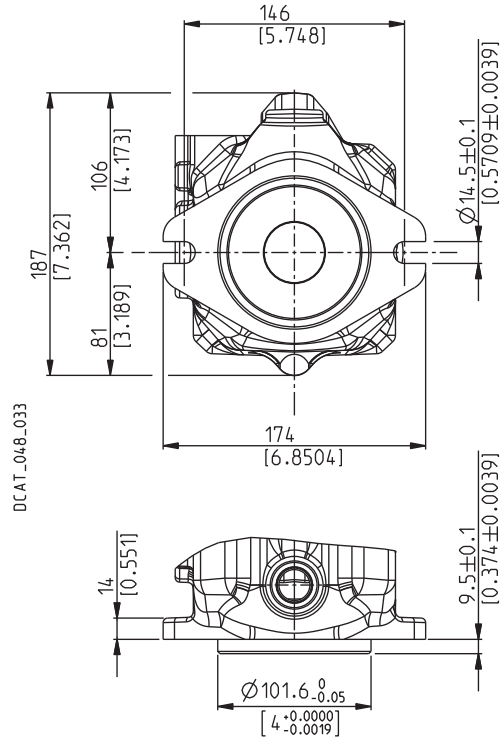

SAE "BB" SPLINE

05

Mounting face refers to flange code **S5**

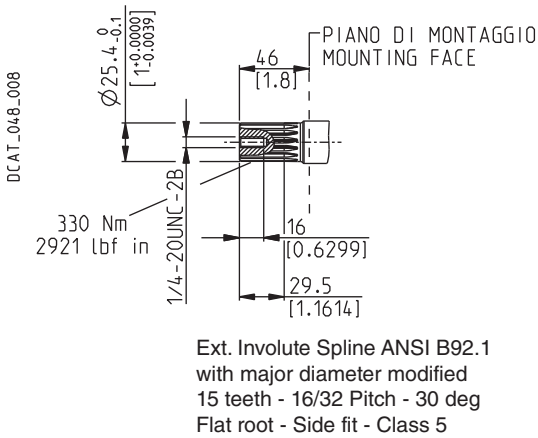

SAE "B" STRAIGHT

32

Mounting face refers to flange code **S5**

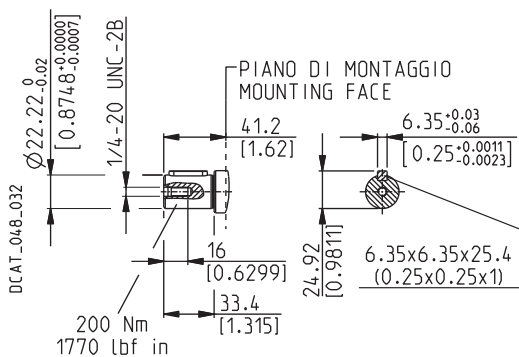

03/06.2011

MVP60

SIDE PORTS - DIMENSIONS

L

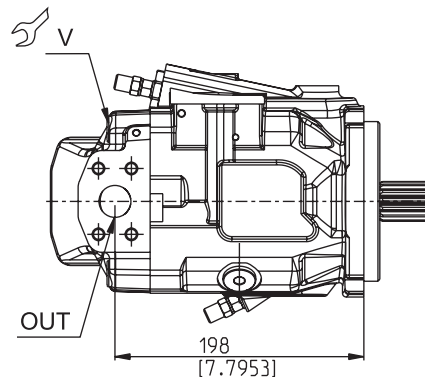
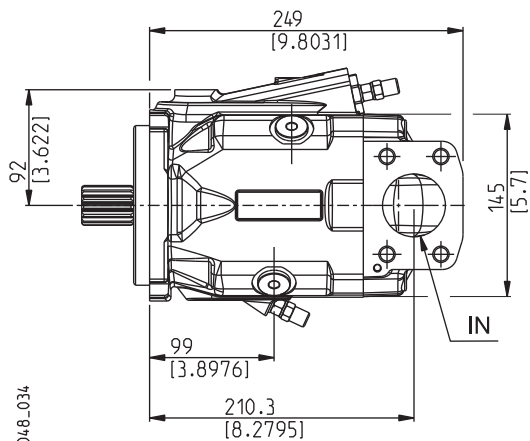

DCAT_048_034

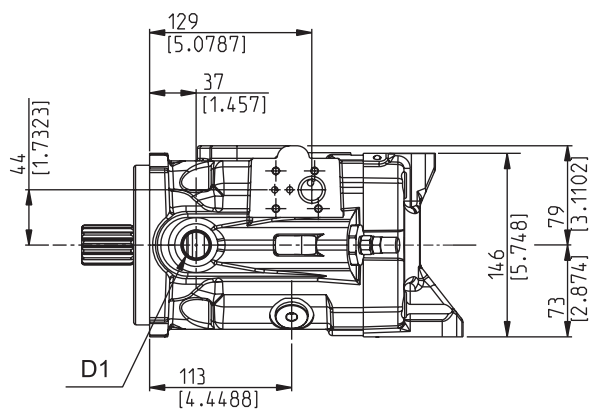

Drive shafts: page 31
Mounting flanges: page 31

03/06.2011

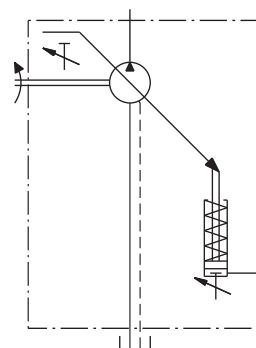

Screws tightening torque Nm (lbf in)

V
130 ±13 (1036 ÷ 1266)

Ports (Nominal size)

IN	OUT	D1
2"	1"	Drain port

Dimensions at page 32

MVP60

REAR PORTS - DIMENSIONS

P

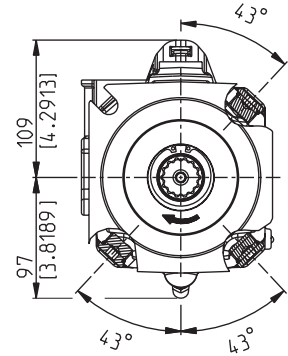
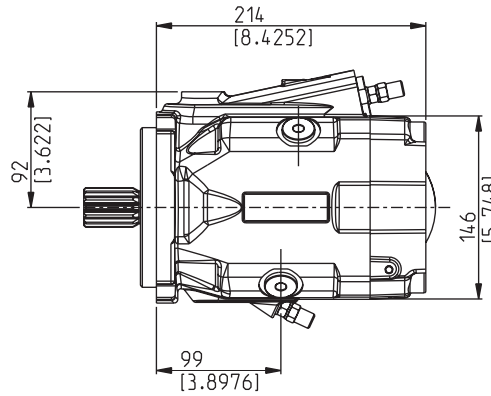
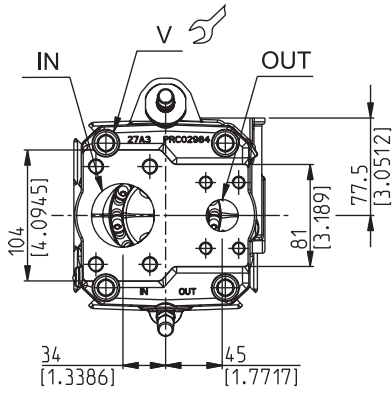

Drive shafts: page 31
Mounting flanges: page 31

DCAT_048_005

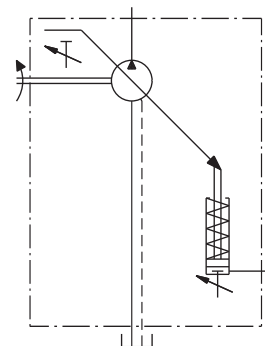
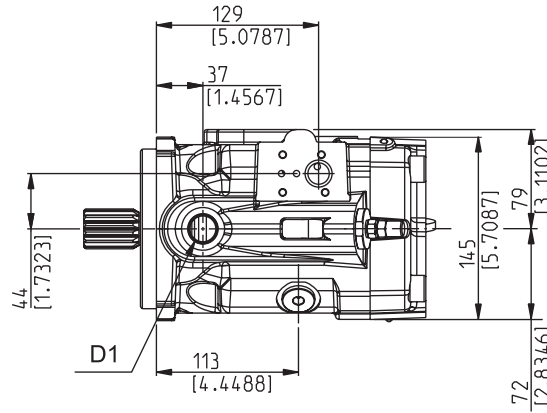
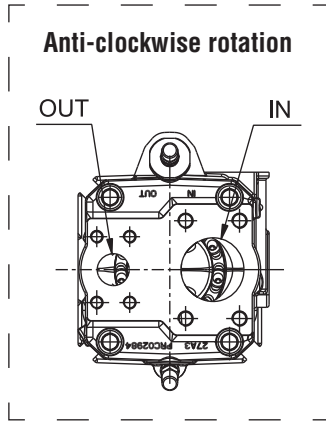

Screws tightening torque Nm (lbf in)

V
130 ±13 (1036 ÷ 1266)

Ports (Nominal size)

IN	OUT	D1
2"	1"	Drain port

Dimensions at page 32

03/06.2011

MVP60/KP20

MULTIPLE PUMPS - DIMENSIONS

L

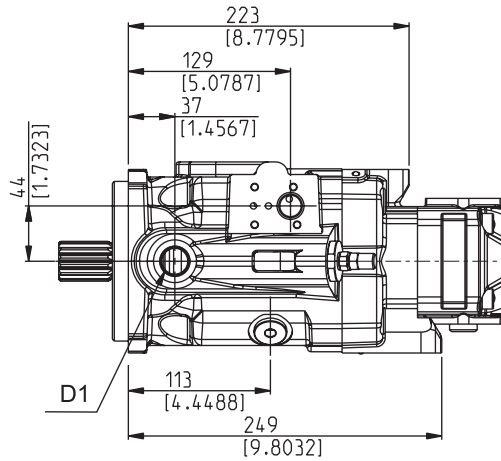
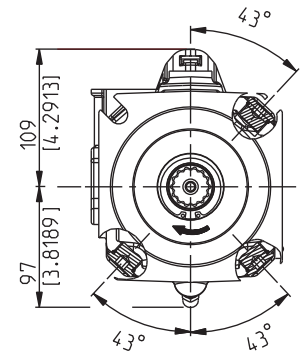
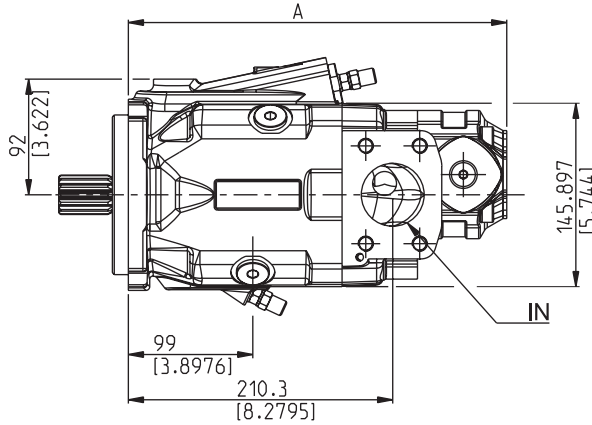
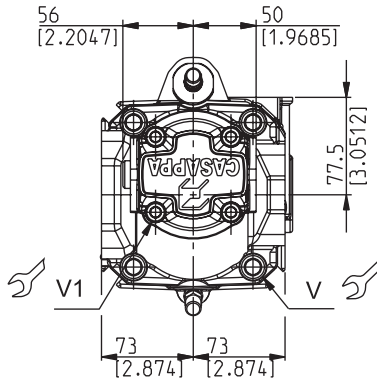

Drive shafts: page 31
Mounting flanges: page 31

DCAT_048_029_KP20

Screws tightening torque Nm (lbf in)

V	V1
130 ±13 (1036 ÷ 1266)	70 ±7 (558 ÷ 682)

Ports (Nominal size)

IN	OUT	D1
MVP	MVP	KP20
2"	1"	1/2"
		Drain port

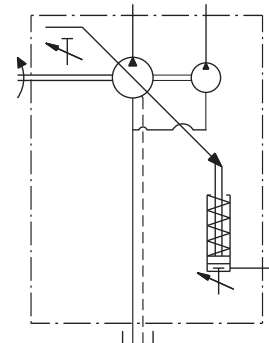
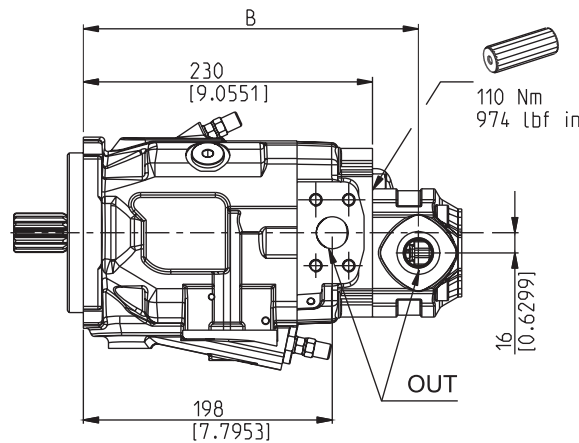

03/06.2011

Dimensions at page 32

Gear pump KAPPA

Pump type	Mounting flange	20•4	20•6,3	20•8	20•11,2	20•14	20•16	20•20	Dimensions
MVP60	S5 - S8	281,5 (11.0827)	284 (11.1811)	286,5 (11.2795)	290 (11.4173)	294 (11.5748)	299,5 (11.7913)	306 (12.0472)	mm (in) A
		254 (10.000)	256,5 (10.0894)	259 (10.1969)	262,5 (10.3346)	261 (10.2756)	266,5 (10.4921)	273 (10.7480)	mm (in) B

MVP60/PHP20

MULTIPLE PUMPS - DIMENSIONS

L

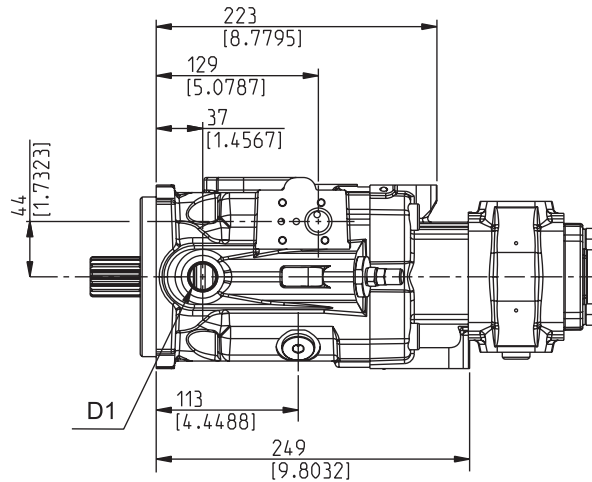
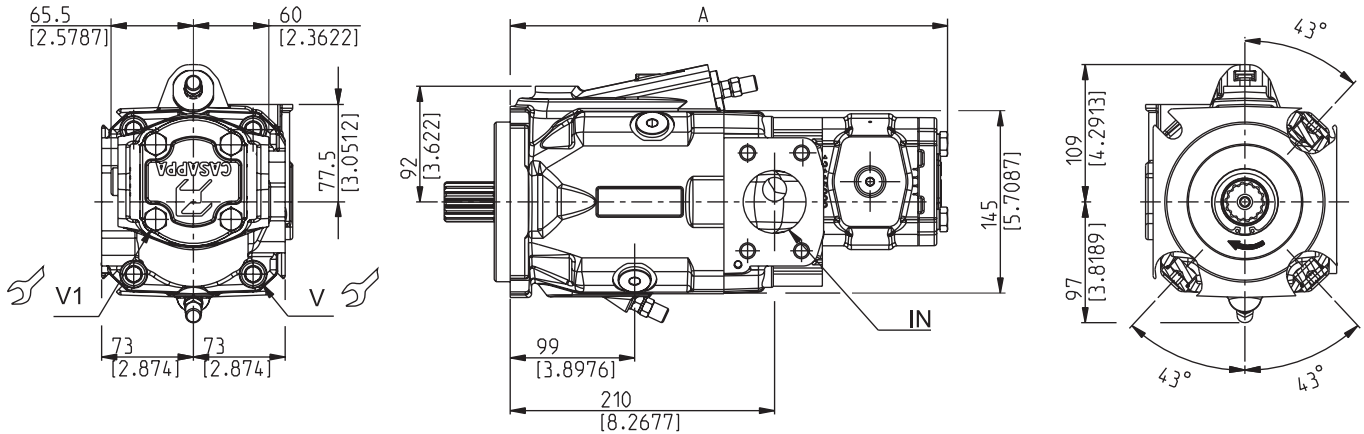

Drive shafts: page 31
Mounting flanges: page 31

Also available in combination with PLP20

Screws tightening torque Nm (lbf in)

V	V1
130 ±13 (1036 ÷ 1266)	70 ±7 (558 ÷ 682)

Ports (Nominal size)

IN	OUT	D1
MVP	MVP	PHP20
2"	1"	1/2"
		Drain port

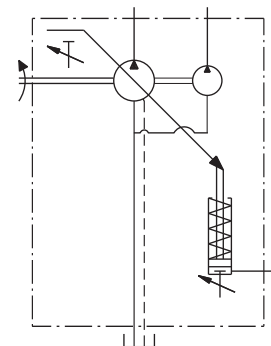
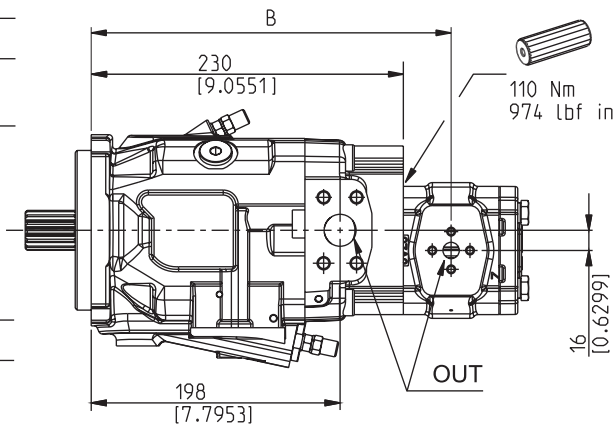

Dimensions at page 32

Gear pump POLARIS PH

Pump type	Mounting flange	20•19	20•20	20•23	20•24,5	20•25	20•27,8	20•31,5	Dimensions
MVP60	S5 - S8	326,5 (12.8543)	329,6 (12.9764)	332,9 (13.1063)	335,2 (13.1969)	337,6 (13.2913)	340,3 (13.3976)	347,6 (13.6850)	mm (in) A
		266,45 (10.4902)	268 (10.5512)	269,65 (10.6161)	270,8 (10.6614)	272 (10.7087)	273,35 (10.7618)	277 (10.9055)	mm (in) B

03/06.2011

MVP60

DRIVE SHAFTS / MOUNTING FLANGES

SAE "BB" SPLINE

05

Mounting face refers to flange code **S5**

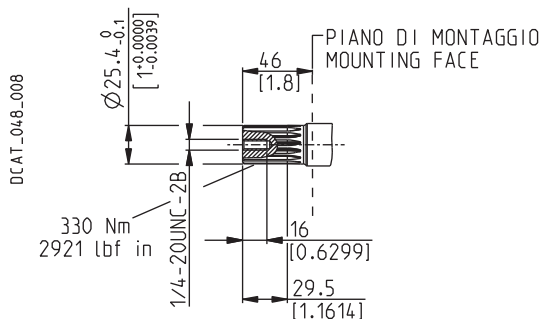

Ext. Involute Spline ANSI B92.1
with major diameter modified
15 teeth - 16/32 Pitch - 30 deg
Flat root - Side fit - Class 5

SAE "C" SPLINE

06

Mounting face refers to flange code **S8**

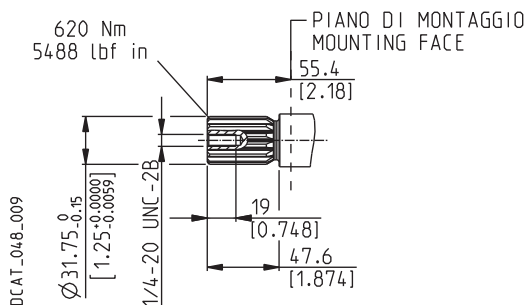

Ext. Involute Spline ANSI B92.1
with major diameter modified
14 teeth - 12/24 Pitch - 30 deg
Flat root - Side fit - Class 5

SAE "C" STRAIGHT

34

Mounting face refers to flange code **S8**

03/06.2011

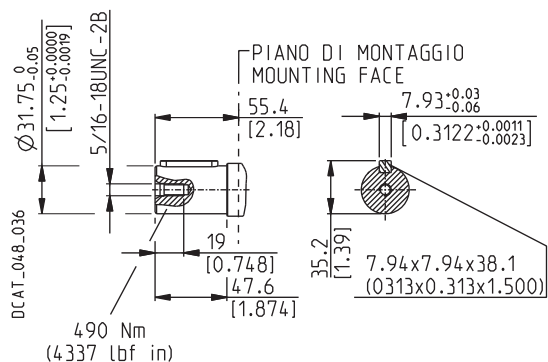

SAE "B" 2 HOLES

S5

Conforms to SAE J744

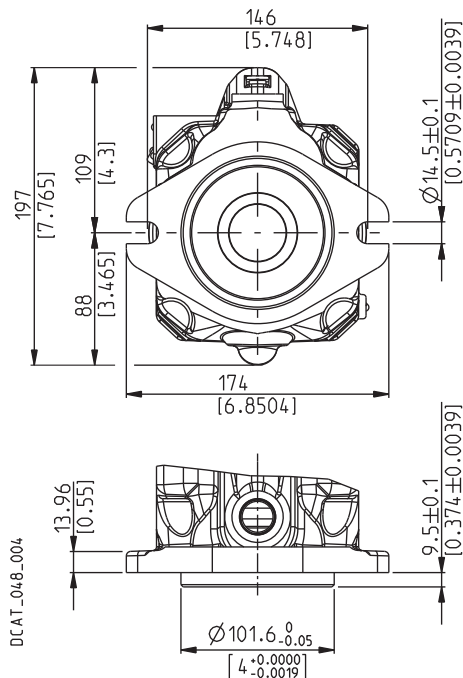

SAE "C" 4 HOLES

S8

Conforms to SAE J744

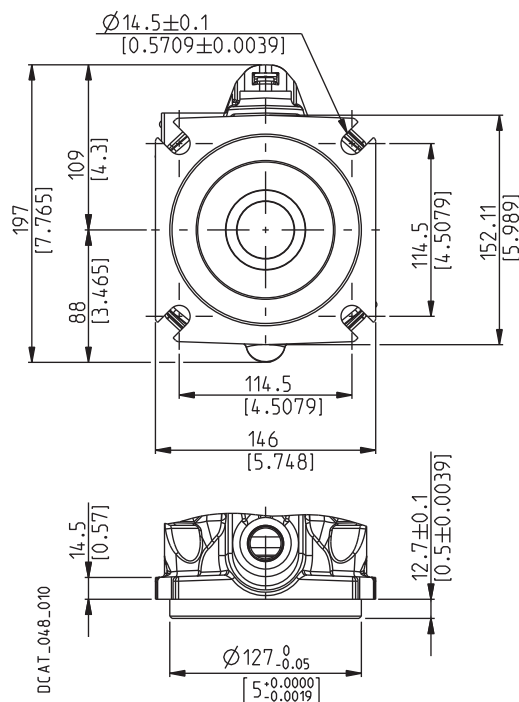

PORTS SIZES

Ports type	INLET / OUTLET PORTS						DRAIN PORTS		LOAD SENSING PORTS		KP20 / PHP20 GEAR PUMPS	
	Split SSM		Split SSS		SAE ODT		Gas BSPPP	SAE ODT (●)	Gas BSPPP	SAE ODT (●)	Gas BSPPP	SAE ODT
	IN	OUT	IN	OUT	IN	OUT	D1	D1	X	X	OUT	OUT
MVP 30	MD	MB	SD	SB	—	—	—	OB	GA	03	GD	OC
MVP 48	ME	MC	SE	SC	OH	OF	GD	OC	GA	03	GD	OC
MVP 60	MF	MC	SF	SC	MF	OF	GD	OC	GA	03	GD	OC

(●) Available only with inlet and outlet ports type Split SSS and SAE ODT.



Tightening torque for low pressure side port



Tightening torque for high pressure side port [values obtained at 350 bar (5075 psi)]

SAE FLANGED PORTS J518 - Standard pressure series 3000 psi **SSM**

Metric thread ISO 60° conforms to ISO/R 262

CODE	Nominal size	A	B	C	D		
		mm (in)	mm (in)	mm (in)	Thread Depth mm (in)	Nm (lbf in)	Nm (lbf in)
MB	3/4"	20 (0.7874)	47,6 (1.8740)	22,2 (0.8740)	M 10 17 (0.6693)	—	45 ^{+2,5} (398 ÷ 420)
MC	1"	25,4 (1.0000)	52,4 (2.0630)	26,2 (1.0315)	M 10 17 (0.6693)	—	30 ^{+2,5} (266 ÷ 288)
MD	1" 1/4	32 (1.2598)	58,7 (2.3110)	30,2 (1.1890)	M 10 17 (0.6693)	20 ⁺¹ (177 ÷ 186)	—
ME	1" 1/2	38,1 (1.5000)	69,8 (2.7480)	35,7 (1.4055)	M 12 20 (0.7874)	30 ^{+2,5} (266 ÷ 288)	—
MF	2"	51 (2.0079)	77,8 (3.0630)	42,9 (1.6890)	M 12 20 (0.7874)	30 ^{+2,5} (266 ÷ 288)	—

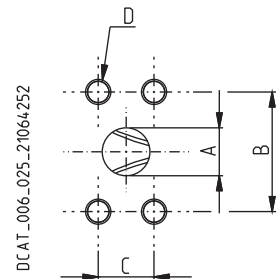

SAE FLANGED PORTS J518 - Standard pressure series 3000 psi **SSS**

American straight thread UNC-UNF 60° conforms to ANSI B 1.1

CODE	Nominal size	A	B	C	D		
		mm (in)	mm (in)	mm (in)	Thread Depth mm (in)	Nm (lbf in)	Nm (lbf in)
SB	3/4"	20 (0.7874)	47,6 (1.8740)	22,2 (0.8740)	3/8 - 16 UNC-2B 17 (0.6693)	—	30 ^{+2,5} (266 ÷ 288)
SC	1"	25,4 (1.0000)	52,4 (2.0630)	26,2 (1.0315)	3/8 - 16 UNC-2B 17 (0.6693)	—	35 ^{+2,5} (310 ÷ 332)
SD	1" 1/4	32 (1.2598)	58,7 (2.3110)	30,2 (1.1890)	7/16 - 14 UNC-2B 17 (0.6693)	25 ⁺¹ (221 ÷ 230)	—
SE	1" 1/2	38,1 (1.5000)	69,8 (2.7480)	35,7 (1.4055)	1/2 - 13 UNC-2B 20 (0.7874)	30 ^{+2,5} (266 ÷ 288)	—
SF	2"	51 (2.0079)	77,8 (3.0630)	42,9 (1.6890)	1/2 - 13 UNC-2B 20 (0.7874)	30 ^{+2,5} (266 ÷ 288)	—

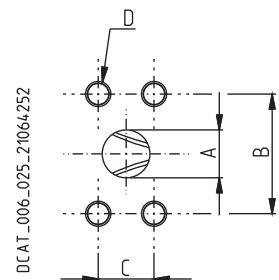

03/06.2011

PORTS SIZES

 Tightening torque for low pressure side port



 Tightening torque for high pressure side port [values obtained at 350 bar (5075 psi)]

SAE STRAIGHT THREAD PORTS J514

ODT

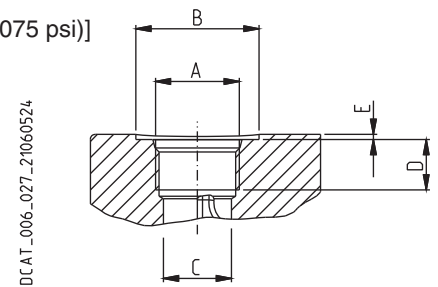
American straight thread UNC-UNF 60° conforms to ANSI B 1.1



CODE	Nominal size	A	Ø B	Ø C	D	E		
							Nm (lbf in)	Nm (lbf in)
03 (X)	1/4"	7/16" - 20 UNF - 2B	—	9,5 (0.3740)	—	—	—	12 ⁺¹ (106 ÷ 115)
0B (●)	1/2"	3/4" - 16 UNF - 2B	33 (1.2992)	17, (1.3780)	—	1 (0.0394)	20 ⁺¹ (177 ÷ 186)	—
0C (●)	5/8"	7/8" - 14 UNF - 2B	35 (1.3780)	20,5 (0.8071)	—	2 (0.0787)	30 ^{+2,5} (266 ÷ 288)	—
0C (◆)			34 (1.3386)	20,5 (0.8071)	17 (0.6693)	0,5 (0.0197)	—	70 ⁺⁵ (620 ÷ 664)
0F	1"	1 5/16" - 12 UNF - 2B	—	30,5 (1.2008)	20 (0.7874)	—	—	170 ⁺¹⁰ (1505 ÷ 1593)
0H	1" 1/2	1 7/8" - 12 UNF - 2B	—	45 (1.7717)	20 (0.7874)	—	100 ⁺⁵ (885 ÷ 929)	—

(X) = Load sensing port

(●) = Drain port



(◆) = KP20 / PHP20 outlet port

GAS STRAIGHT THREAD PORTS

BSPP

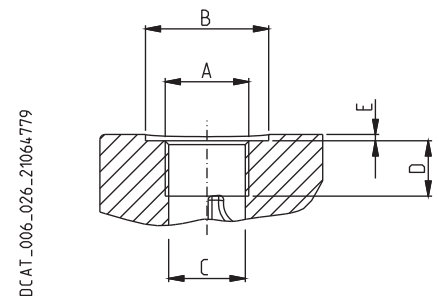
British standard pipe parallel (55°) conforms to UNI - ISO 228



CODE	Nominal size	A	Ø B	Ø C	D	E		
							Nm (lbf in)	Nm (lbf in)
GA (X)	1/8"	G 1/8	—	8,75 (0.3444)	12 (0.4724)	—	—	5 ^{+0,25} (44 ÷ 46)
GD (●)	1/2"	G 1/2	30 (1.1811)	19 (0.7480)	17 (0.6693)	2 (0.0787)	20 ⁺¹ (177 ÷ 186)	—
GD (◆)			—	19 (0.7480)	17 (0.6693)	—	—	50 ^{+2,5} (443 ÷ 465)

(X) = Load sensing port

(●) = Drain port

(◆) = KP20 / PHP20 outlet port

03/06.2011

PRESSURE COMPENSATOR

RPO

Regulates the pump displacement automatically to maintain the pressure below the fixed pre-adjusted limit.

Compensator type	Pump type	Pressure setting range	Standard setting
		bar (psi)	bar (psi)
RPO	MVP 30-28	20 ÷ 280 (290 ÷ 4060)	280 (4060)
	MVP 30-34	20 ÷ 250 (290 ÷ 3625)	250 (3625)
	MVP 48-45	20 ÷ 280 (290 ÷ 4060)	280 (4060)
	MVP 48-53	20 ÷ 250 (290 ÷ 3625)	250 (3625)
	MVP 60-60	20 ÷ 280 (290 ÷ 4060)	280 (4060)
	MVP 60-72	20 ÷ 280 (290 ÷ 4060)	280 (4060)
	MVP 60-84	20 ÷ 250 (290 ÷ 3625)	250 (3625)

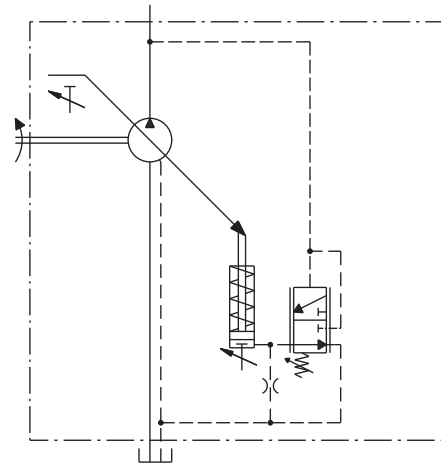

OPERATING CURVES

Curves have been obtained at the speed of 1500 min⁻¹ and oil temperature 50 °C (122 °F).

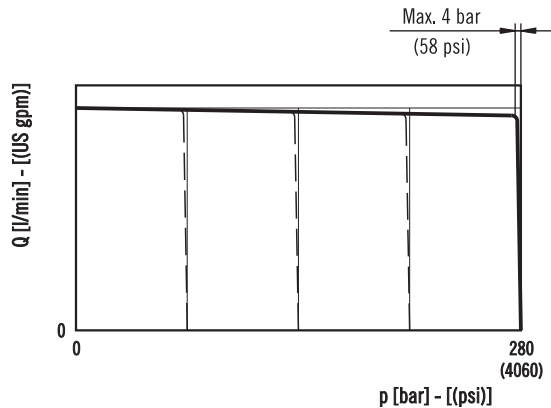

REMOTE CONTROL

For remote pressure compensator LS3 see page 42.

RESPONSE AND RECOVERY TIME

According to SAE J745 (using outlet pressure).

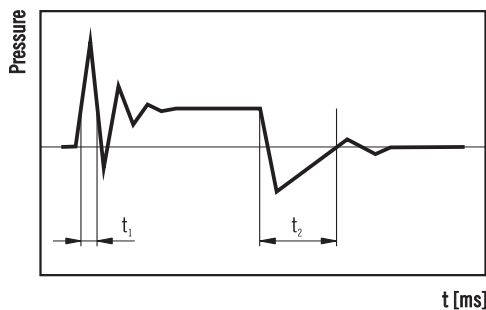

Pump type	t_1 Response time [ms] (off stroke)	t_2 Recovery time [ms] (on stroke)
MVP 30	46	150
MVP 48	48	150
MVP 60	50	150

03/06.2011

PRESSURE COMPENSATOR

RPO

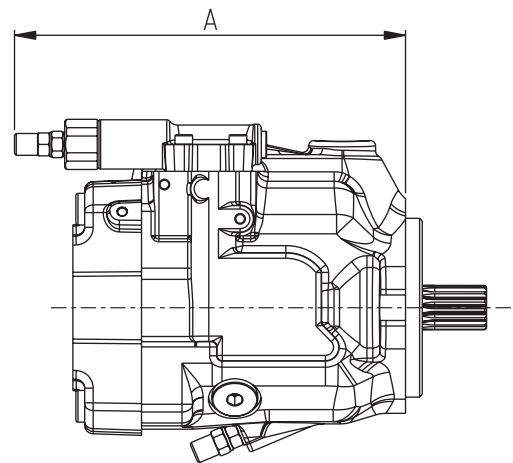
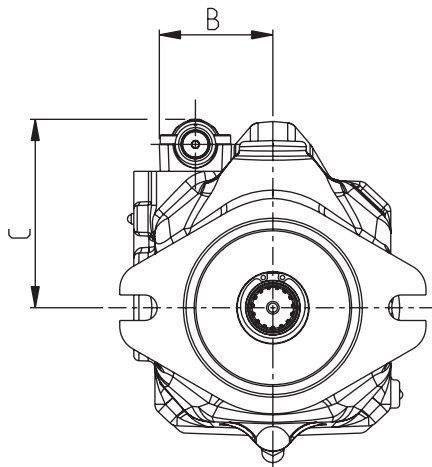
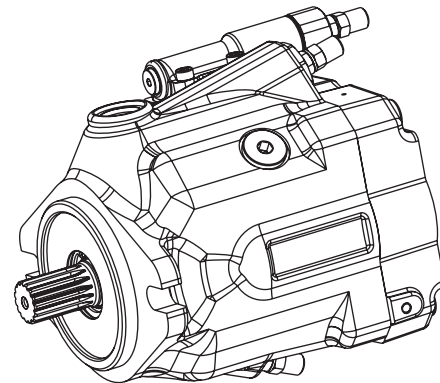

DCAT_048_041

03/06.2011

Pump type	A	B	C
	mm (in)	mm (in)	mm (in)
MVP 30	203 (7.9921)	59,5 (2.3425)	101 (3.9764)
MVP 48	222 (8.7402)	64 (2.5197)	107 (4.2126)
MVP 60	227 (8.9370)	64 (2.5197)	107 (4.2126)

PRESSURE COMPENSATOR

RP1

Regulates the pump displacement automatically to maintain the pressure below the fixed pre-adjusted limit.
Designed to work at high frequency ≥ 1 cycle/min and/or at pressure > 280 bar (4060 psi).

RP1

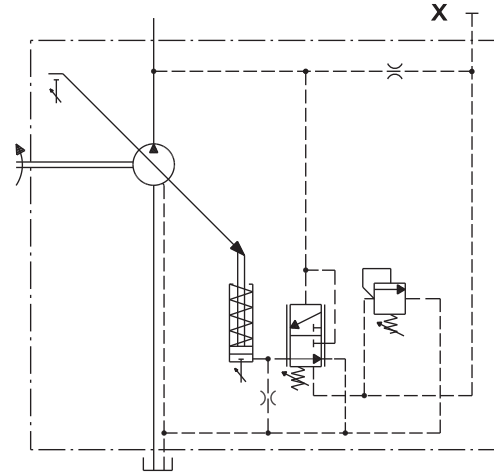

Replaces: 03/06.2011

OPERATING CURVES

Curves have been obtained at the speed of 1500 min^{-1} and oil temperature $50 \text{ }^\circ\text{C}$ ($122 \text{ }^\circ\text{F}$).

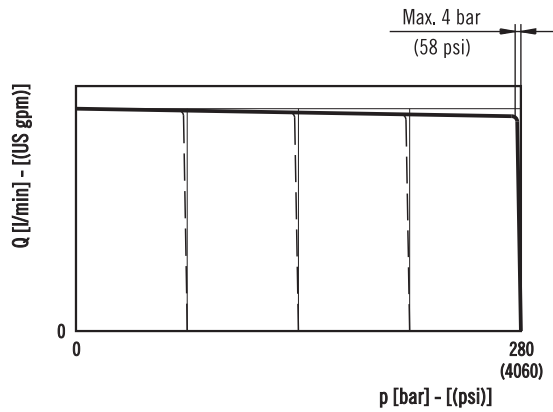

RP1 - LS2 (with flow control)

Not included in supply

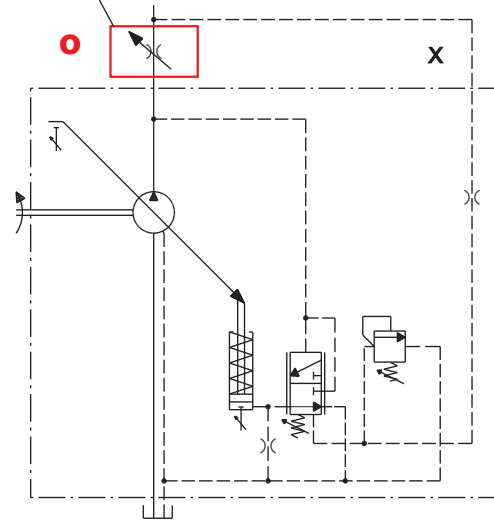

04/01.2012

PRESSURE COMPENSATOR

RP1

03/06.2011

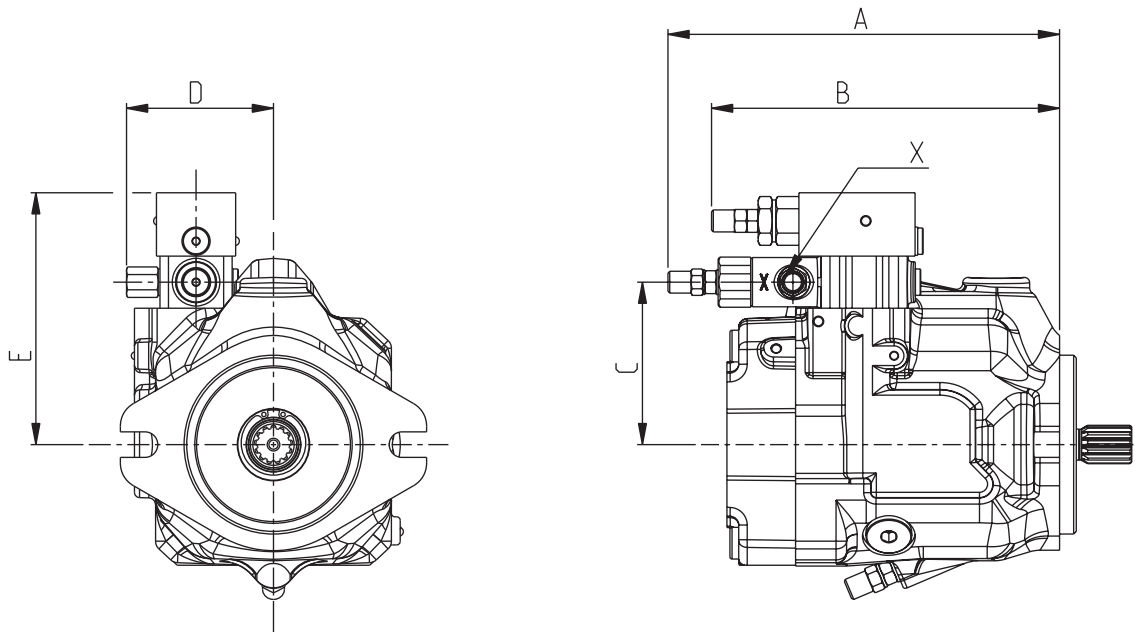
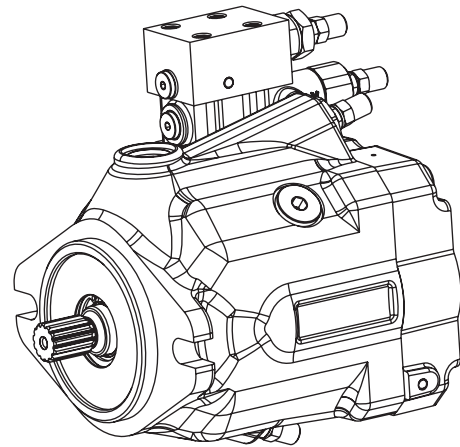

DCAT_048_045

RP1 - LS2 configuration shown.

03/06.2011

Pump type	A	B	C	D	E
	mm (in)	mm (in)	mm (in)	mm (in)	mm (in)
MVP 30	203 (7.9921)	178 (7.0079)	89 (3.5039)	89 (3.5039)	137 (5.3937)
MVP 48	222 (8.7402)	198 (7.7953)	92 (3.6220)	101 (3.9764)	143 (5.6299)
MVP 60	227 (8.9370)	203 (7.9921)	92 (3.6220)	101 (3.9764)	143 (5.6299)

X: Load-sensing port. Dimensions at page 32

DUAL SETTING PRESSURE COMPENSATOR

RP2

Regulates the pump displacement automatically to maintain the pressure below two fixed pre-adjusted limits. The electrically piloted valve allows to switch between the two different limits.

OPERATING CURVES

Curves have been obtained at the speed of 1500 min⁻¹ and oil temperature 50 °C (122 °F).

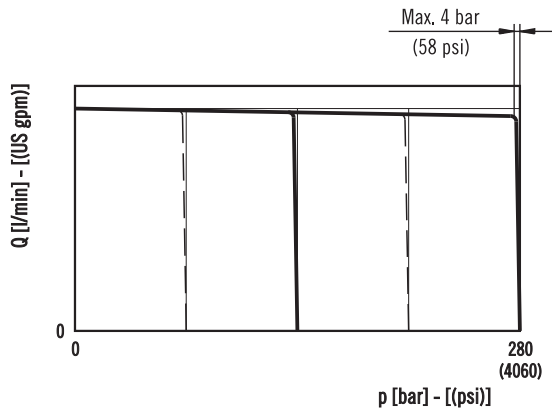

VALVE FEATURES

Valve type	Arrangement	Volt
1	Normally closed	12 VDC
2	Normally closed	24 VDC
3	Normally closed	24 VAC
6	Normally open	12 VDC
7	Normally open	24 VDC
8	Normally open	24 VAC

RP2

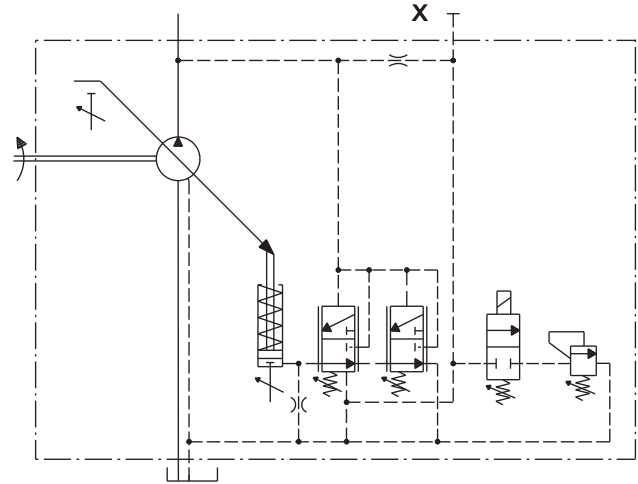

Replaces: 03/06.2011

RP2 - LS2 (with flow control)

Not included in supply

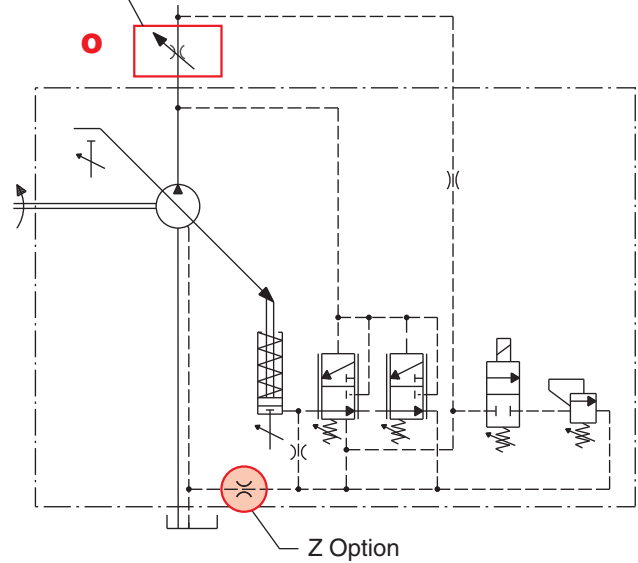

Z Option

Damping restrictor for critical applications. In case of system instability or pressure oscillations, the additional damping restrictor slows down the pump control system, damping the regulation transients. The pump regulation response time increases. The use of the damping restrictor must be evaluated and approved by Casappa technical sales department for the specific application.

04/01.2012

DUAL SETTING PRESSURE COMPENSATOR

RP2

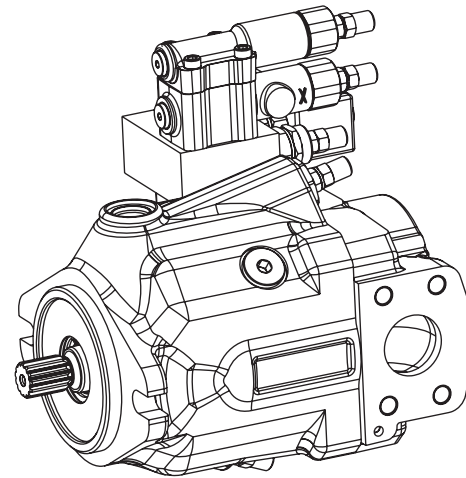

DCAT_048_046

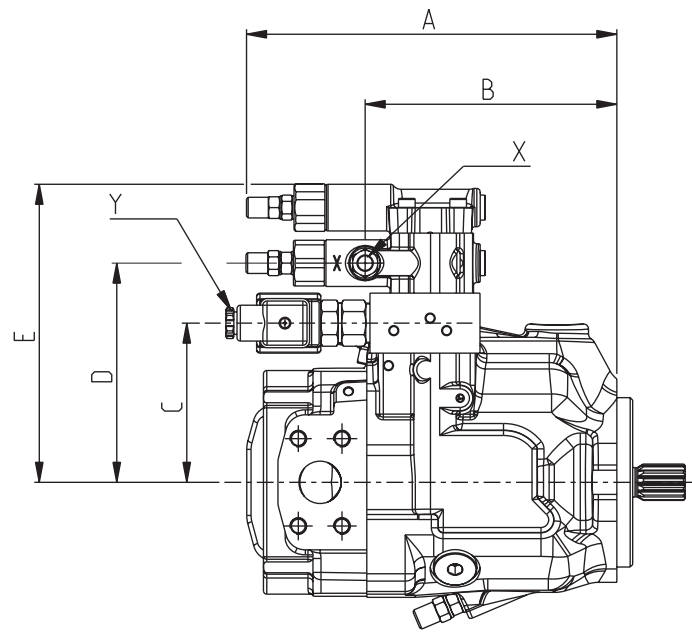
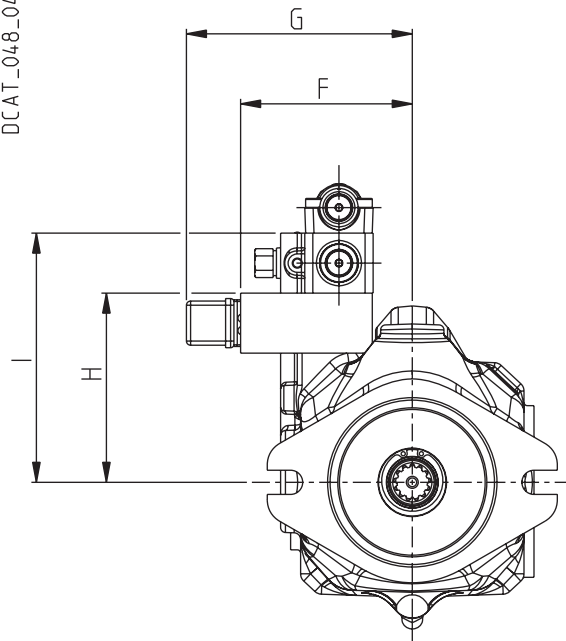

RP2 - LS2 configuration shown.

03/06.2011

Pump type	A	B	C	D	E	F	G	H	I
	mm (in)	mm (in)	mm (in)	mm (in)	mm (in)	mm (in)	mm (in)	mm (in)	mm (in)
MVP 30	203 (7.9921)	131 (5.1575)	89 (3.5039)	125 (4.9213)	172 (6.7717)	98 (3.8583)	130 (5.1181)	89 (3.5039)	143 (5.6299)
MVP 48	222 (8.7402)	151 (5.9449)	95 (3.7402)	131 (5.1575)	179 (7.0472)	103 (4.0551)	135 (5.3150)	113 (4.4488)	149 (5.8661)
MVP 60	227 (8.9370)	156 (6.1417)	95 (3.7402)	131 (5.1575)	179 (7.0472)	103 (4.0551)	135 (5.3150)	113 (4.4488)	149 (5.8661)

X: Load-sensing port. Dimensions at page 32

Y: Connector. Standard type DIN 43 650 / ISO 4400. For other connectors please consult our technical sales department.

ELECTRO-PROPORTIONAL PRESSURE COMPENSATOR

PEC

Regulates the pump displacement automatically to maintain the pressure below the variable limit set through a command current signal.

OPERATING CURVES

Curves have been obtained at the speed of 1500 min⁻¹ and oil temperature 50 °C (122 °F).

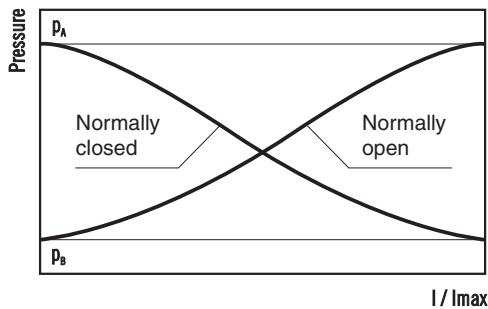

VALVE FEATURES

Valve type	Arrangement	Volt
1	Normally closed	12 VDC
2	Normally closed	24 VDC
6	Normally open	12 VDC
7	Normally open	24 VDC

Volt	12 V (+/- 10%)	24 V (+/- 10%)
Control current	50 ÷ 1200 mA	50 ÷ 600 mA
Limit current	1,25 A	0,63 A
Dither frequency	150 Hz	150 Hz
Operating temperature	-40 °C ÷ 100 °C (-40 °F ÷ 212 °F)	
P_B Pressure range	25 ÷ 100 bar (363 ÷ 1450 psi)	
P_A Pressure range	210 ÷ 310 (3045 ÷ 4495 psi)	
Connector type	DIN 43 650 / ISO 4400 or DEUTSCH	

PEC

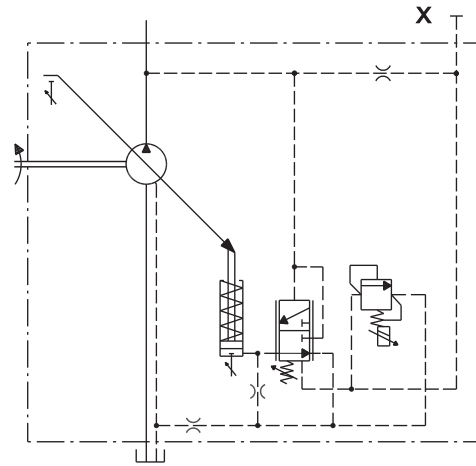

PEC - LS2 (with flow control)

Not included in supply

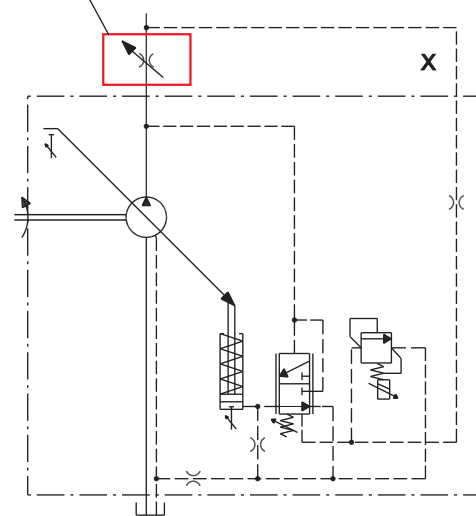

03/06.2011

ELECTRO-PROPORTIONAL PRESSURE COMPENSATOR

PEC

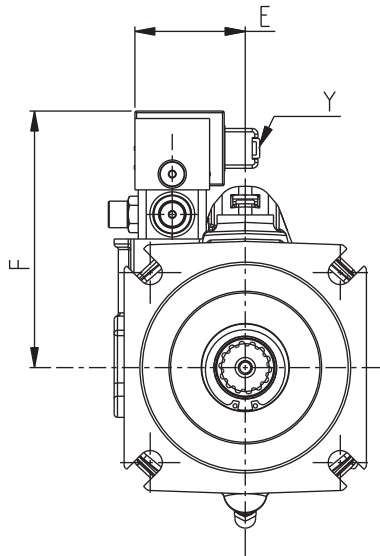
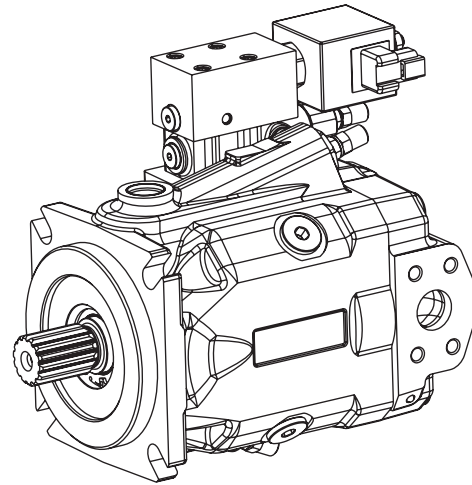

DCAT_048_050

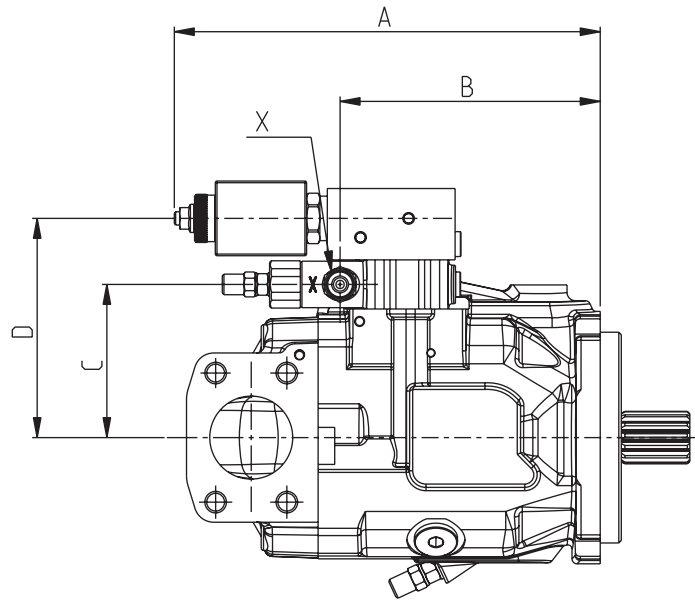

03/06.2011

Pump type	A mm (in)	B mm (in)	C mm (in)	D mm (in)	E mm (in)	F mm (in)
MVP 30	203 (7.9921)	131 (5.1575)	86 (3.3858)	126 (4.9606)	61 (2.4016)	148 (5.8268)
MVP 48	251 (9.8819)	151 (5.9449)	92 (3.6220)	132 (5.1969)	66 (2.5984)	155 (6.1024)
MVP 60	256 (10.0787)	156 (6.1417)	92 (3.6220)	132 (5.1969)	66 (2.5984)	155 (6.1024)

X: Load-sensing port. Dimensions at page 32
Y: Connector type DIN 43 650 / ISO 4400 or DEUTSCH.

FLOW COMPENSATOR (Load-sensing)

LS

Regulates the pump displacement to maintain a constant (load independent) pressure drop across a flow metering device. In the standard version the flow compensator is combined with pressure compensator.

Flow compensator type	Pressure compensator	Differential pressure setting range	Standard setting
		bar (psi)	bar (psi)
LS0 (■)	RPO		
LS2 (◆)	RPO	10 ÷ 40 (145 ÷ 580)	14 (203)
LS3 (●)	RPO		

- (■): Suggested when the directional control valve does not have the bleed function
- (◆): Y is plugged. Suggested when the directional control valve has the bleed function
- (●): For remote pressure control.

Pilot flow $\approx 1,3 \div 1,5$ l/min (0.34 ÷ 0.40 US gpm)

In standard setting conditions 14 bar (203 psi) the stand-by pressure is $15^{\pm 2}$ bar ($218^{\pm 29}$ psi).

OPERATING CURVES

Curves have been obtained at the speed of 1500 min^{-1} and oil temperature $50 \text{ }^\circ\text{C}$ ($122 \text{ }^\circ\text{F}$).

Curve at variable speed

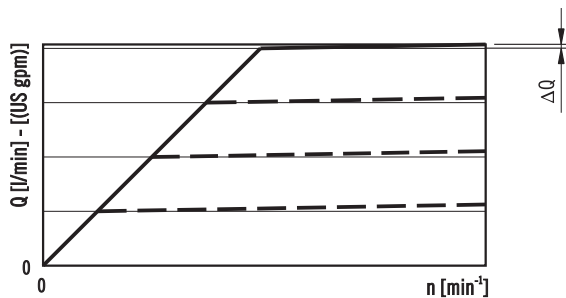

RESPONSE TIME

According to SAE J745 (using outlet pressure).

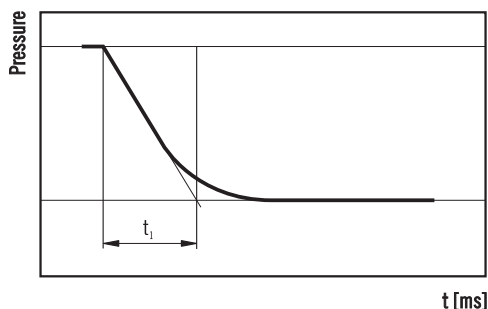

LS0 - LS2

Not included in supply

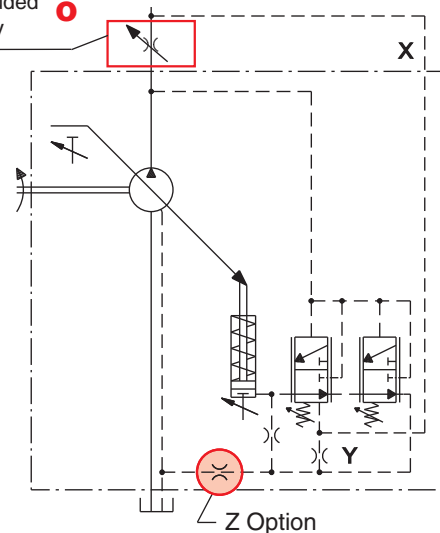

Z Option
(See page 38 for more information)

LS3 - Remote pressure compensator

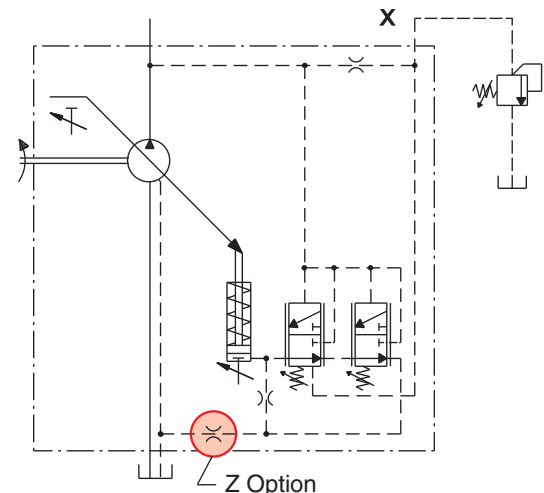

Z Option
(See page 38 for more information)

ΔQ max

Pump type	l/min (US gpm)
MVP 30	0,9 (0.24)
MVP 48	1,7 (0.45)
MVP 60	2,5 (0.66)

t₁

Pump type	Response time [ms] (off stroke)
MVP 30	120
MVP 48	120
MVP 60	120

According to SAE J745 (using outlet pressure)

Replaces: 03/06.2011

04/01.2012

FLOW COMPENSATOR (Load-sensing)

LS

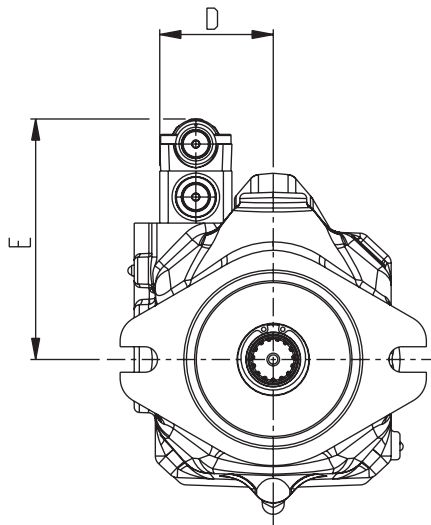
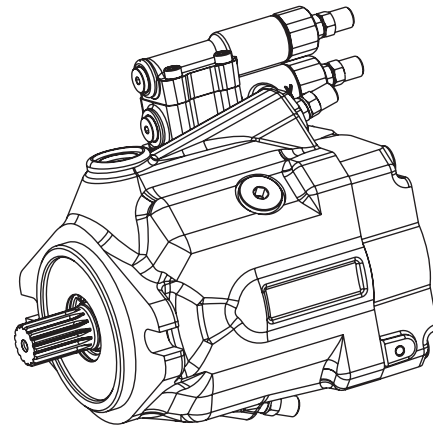

DCAT_048_042

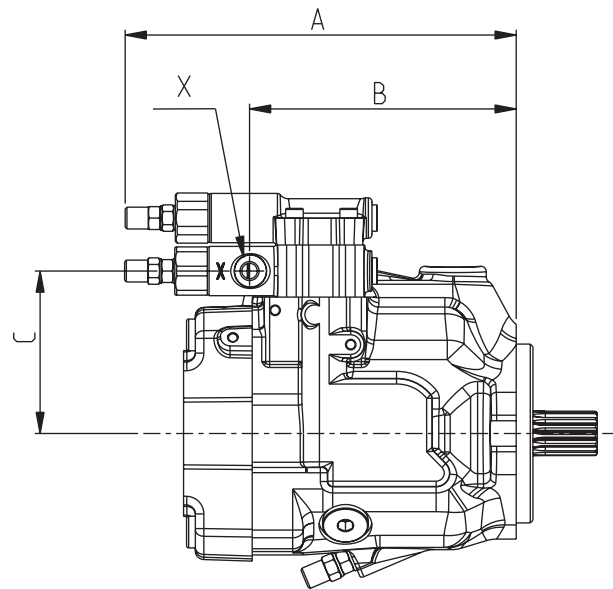

03/06.2011

Pump type	A	B	C	D	E
	mm (in)	mm (in)	mm (in)	mm (in)	mm (in)
MVP 30	203 (7.9921)	131 (5.1575)	89 (3.5039)	59 (2.3228)	137 (5.3937)
MVP 48	222 (8.7402)	151 (5.9449)	96 (3.7795)	64 (2.5197)	143 (5.6299)
MVP 60	227 (8.9370)	156 (6.1417)	96 (3.7795)	64 (2.5197)	143 (5.6299)

X: Load-sensing port. Dimensions at page 32

TORQUE LIMITER

RN

Regulates the pump displacement according to the system pressure, to maintain the pre-adjusted torque value and protect the prime mover from overload. To have the best torque limiter regulation, the pre-adjusted absorbed torque has to be higher than the value shown in the following table.

Pump type	Min. torque	Min. power (●)
	Nm (lbf in)	kW (HP)
MVP 30	45 (398)	7.1 (9,5)
MVP 48	61 (540)	9.6 (12,9)
MVP 60	97 (859)	15.2 (20,4)

(●) @ 1500 min⁻¹

For lower torque setting values, the regulator limits the maximum working pressure to a value lower than the standard setting for the pressure regulator 280 bar (4060 psi). When ordering the torque limiter please specify the requested value of torque [eg. 70 Nm (620 lbf in)] or the requested power and speed [eg. 10 kW (13.4 HP) at 1500 min⁻¹].

OPERATING CURVES

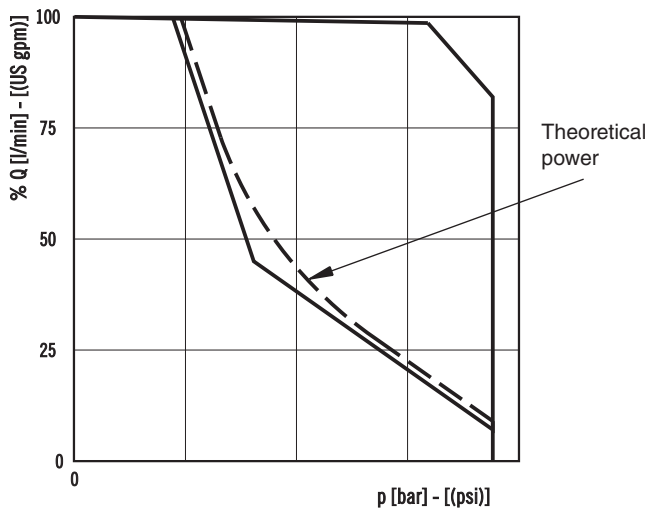

RN0 - Standard

Torque limitation for closed center valve.

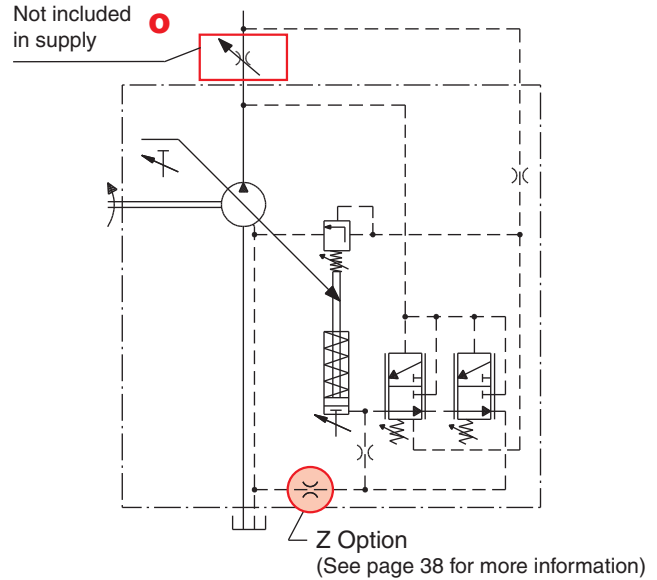

Replaces: 03/06.2011

RN1 - Internal pilot

Torque limitation for open center valve.

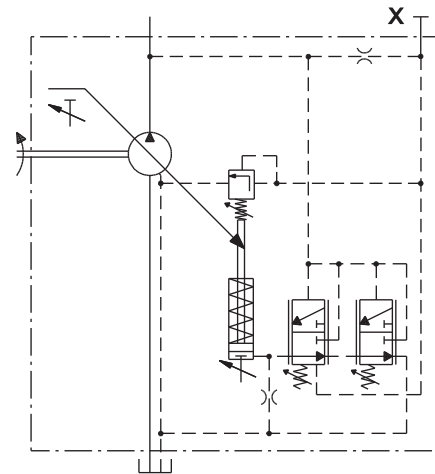

● 04/01.2012

TORQUE LIMITER

RN

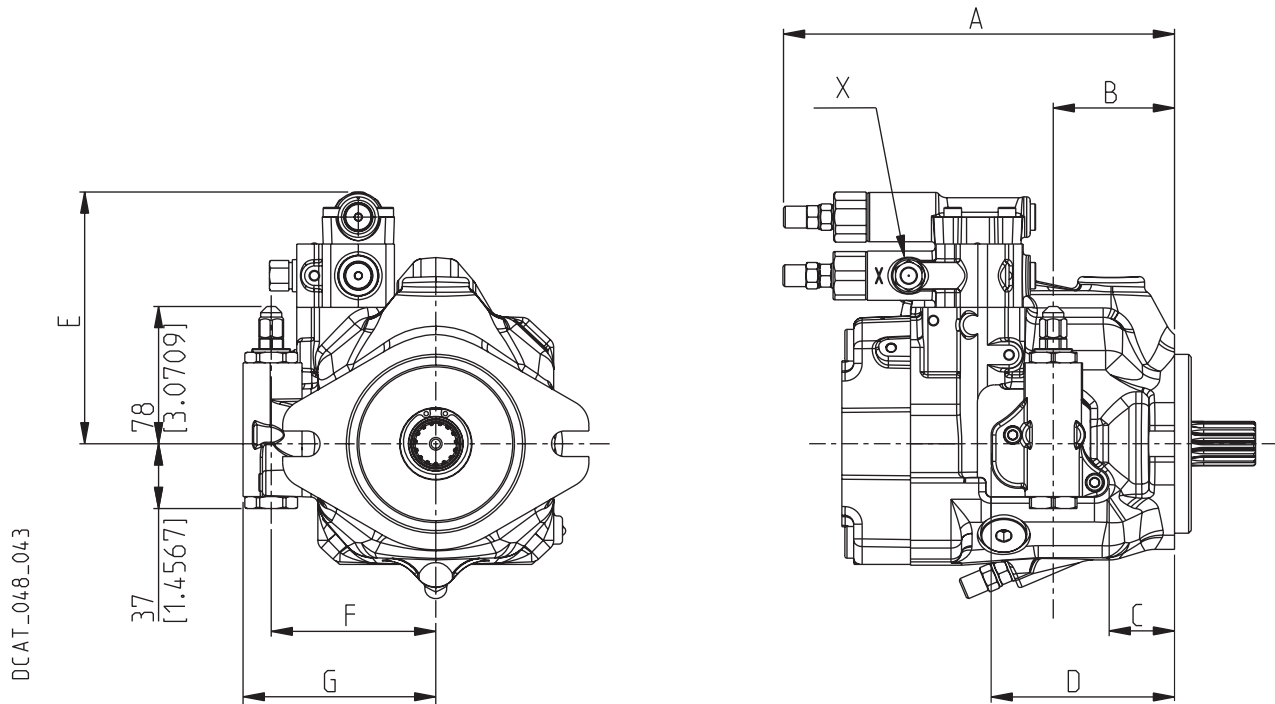
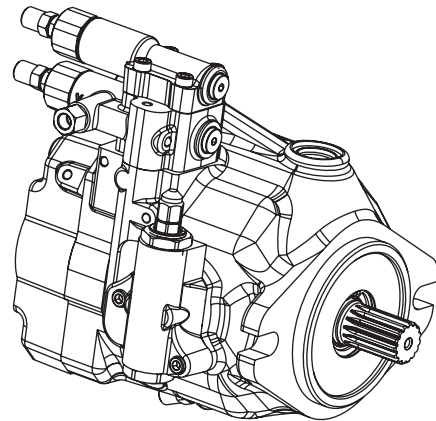

DCAT_048_043

03/06.2011

Pump type	A	B	C	D	E	F	G
	mm (in)	mm (in)	mm (in)	mm (in)	mm (in)	mm (in)	mm (in)
MVP 30	203 (7.9921)	76 (2.9921)	45 (1.7717)	111 (4.3701)	137 (5.3937)	89 (3.5039)	105 (4.1339)
MVP 48	222 (8.7402)	70 (2.7559)	37 (1.4567)	104 (4.0945)	143 (5.6299)	93 (3.6614)	109 (4.2913)
MVP 60	227 (8.9370)	79 (3.1102)	48 (1.8898)	115 (4.5276)	143 (5.6299)	93 (3.6614)	109 (4.2913)

X: Load-sensing port. Dimensions at page 32

DUAL SETTING TORQUE LIMITER

RN2

Regulates the pump displacement automatically to maintain the torque below two fixed pre-adjusted limits. The electrically piloted valve allows to switch between the two different limits.

RN2-LS0 / RN2-LS2

For LS2 configuration Y is plugged.

Pump type	Min. torque	Min. power (●)
	Nm (lbf in)	kW (HP)
MVP 30	45 (398)	7.1 (9,5)
MVP 48	61 (540)	9.6 (12,9)
MVP 60	97 (859)	15.2 (20,4)

(●) @ 1500 min⁻¹

For lower torque setting values, the regulator limits the maximum working pressure to a value lower than the standard setting for the pressure regulator 280 bar (4060 psi).

When ordering the torque limiter please specify the requested value of torque [eg. 70 Nm (620 lbf in)] or the requested power and speed [eg. 10 kW (13.4 HP) at 1500 min⁻¹].

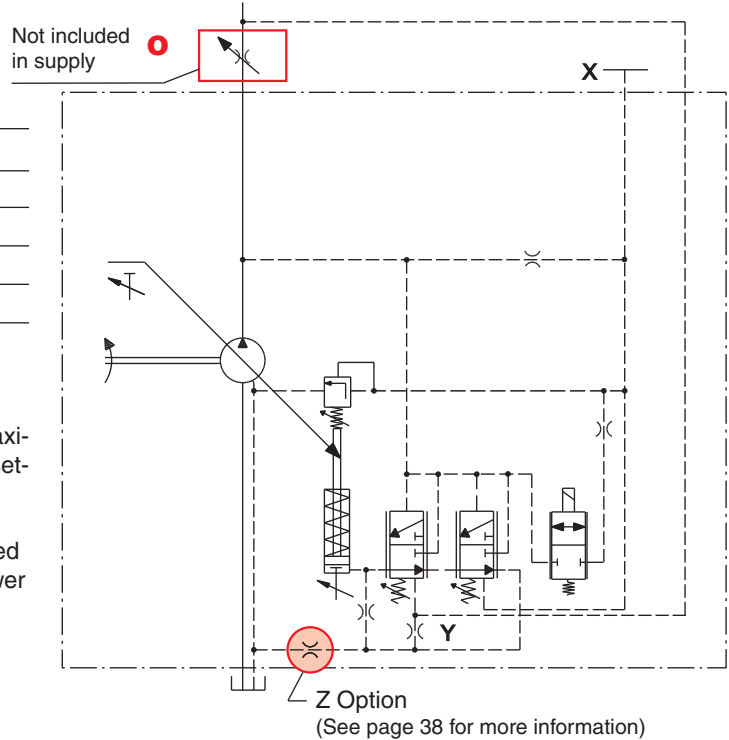

Replaces: 03/06.2011

OPERATING CURVES

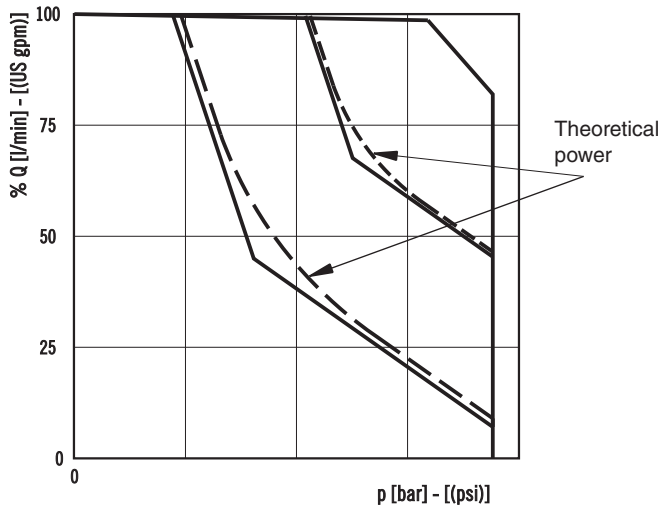

VALVE FEATURES

Valve type	Arrangement	Volt
1	Normally closed	12 VDC
2	Normally closed	24 VDC
6	Normally open	12 VDC
7	Normally open	24 VDC

04/01.2012

DUAL SETTING TORQUE LIMITER

RN2

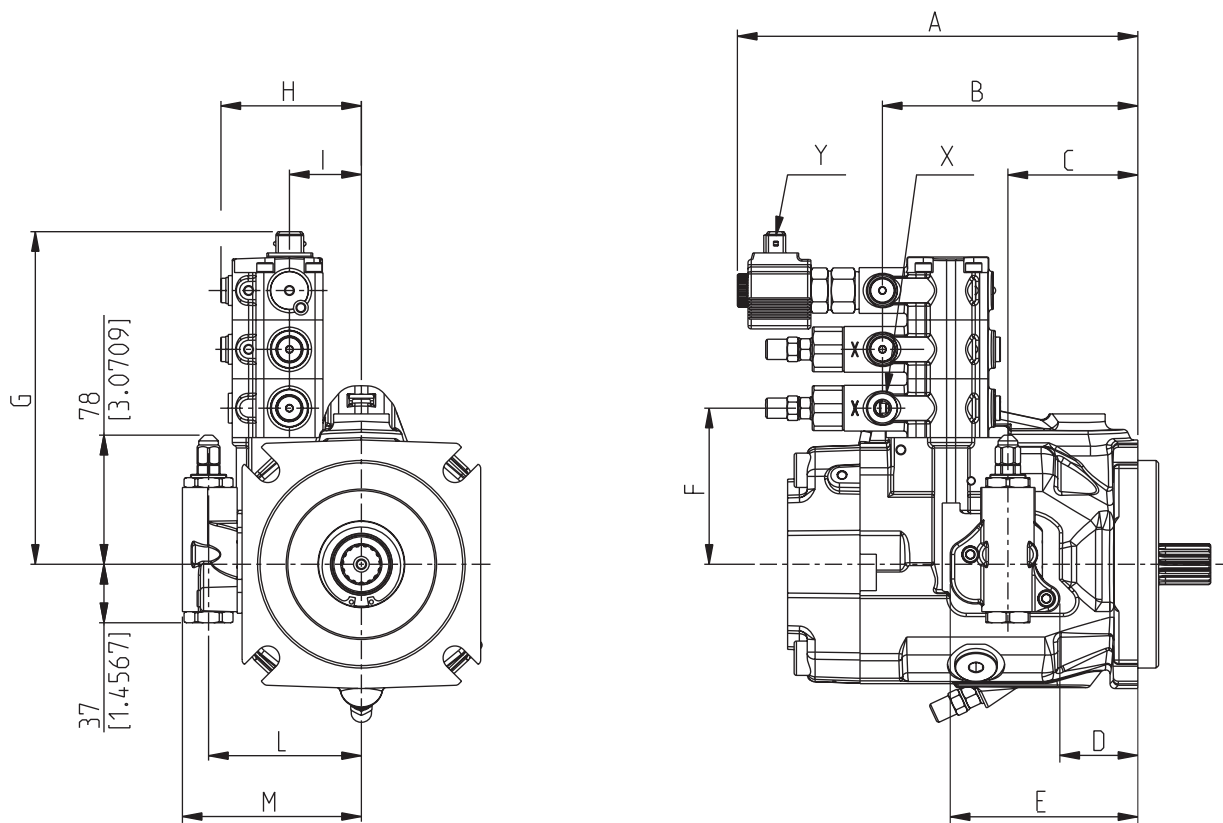
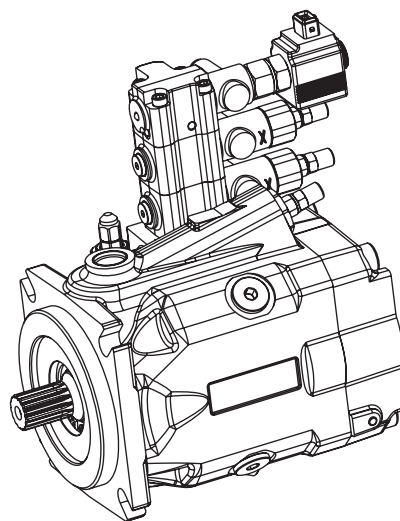

DCAT_048_051

03/06.2011

Pump type	A	B	C	D	E	F	G	H	I	L	M
	mm (in)	mm (in)	mm (in)	mm (in)	mm (in)	mm (in)	mm (in)	mm (in)	mm (in)	mm (in)	mm (in)
MVP 30	220 (8.6614)	131 (5.1575)	76 (2.9921)	45 (1.7717)	111 (4.3701)	89 (3.5039)	181 (7.1260)	81 (3.1890)	39 (1.5354)	89 (3.5039)	105 (4.1339)
MVP 48	240 (9.4488)	151 (5.9449)	70 (2.7559)	37 (1.4567)	104 (4.0945)	96 (3.7795)	188 (7.4016)	85 (3.3465)	44 (1.7323)	93 (3.6614)	109 (4.2913)
MVP 60	245 (9.6457)	156 (6.1417)	79 (3.1102)	48 (1.8898)	115 (4.5276)	96 (3.7795)	188 (7.4016)	85 (3.3465)	44 (1.7323)	93 (3.6614)	109 (4.2913)

X: Load-sensing port. Dimensions at page 32

Y: Connector. Standard type DIN 43 650 / ISO 4400. For other connectors please consult our technical sales department.

UNLOADING VALVE

U ..

NC (normally closed)

NA (normally open)

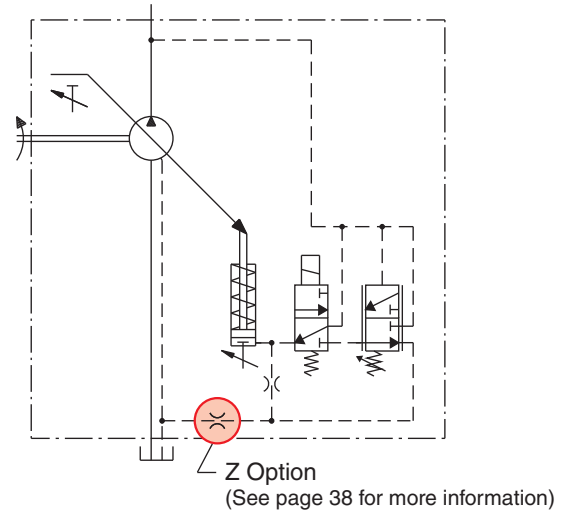
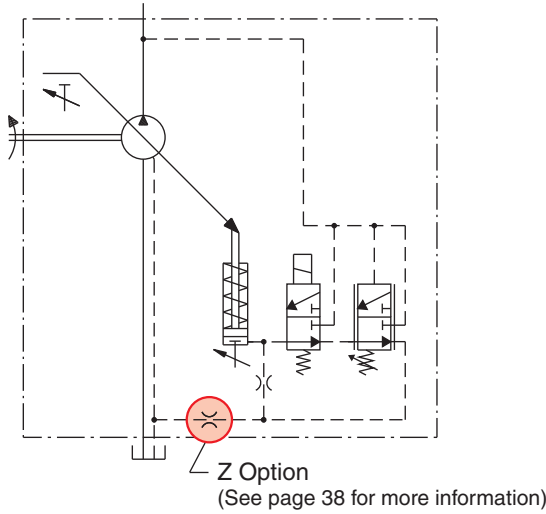

With the valve NC type (normally closed), energizing the solenoid valve the displacement is reset and the pump is unloaded.

With the valve NA type (normally open), energizing the solenoid valve the pump works at the maximum displacement.

NOTES

Unloading valve can be supplied only with pressure compensator RP.

VALVE FEATURES

Valve type	Arrangement	Volt
U1	Normally closed	12 VDC
U2	Normally closed	24 VDC
U3	Normally closed	24 VAC
U4	Normally closed	110 VAC
U5	Normally closed	220 VAC
U6	Normally open	12 VDC
U7	Normally open	24 VDC
U8	Normally open	24 VAC
U9	Normally open	110 VAC
U10	Normally open	220 VAC

03/06.2011

UNLOADING VALVE

U ..

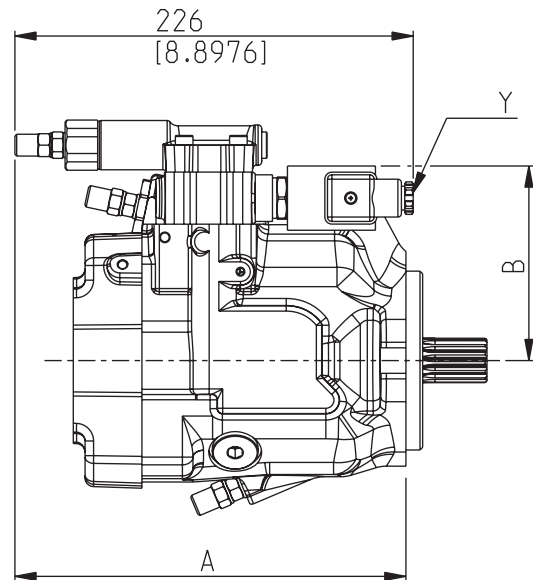
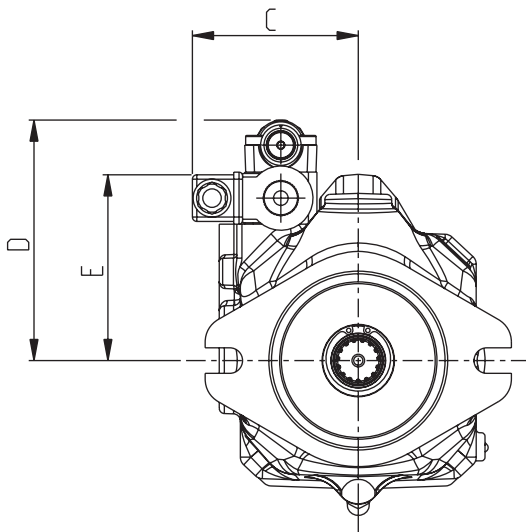
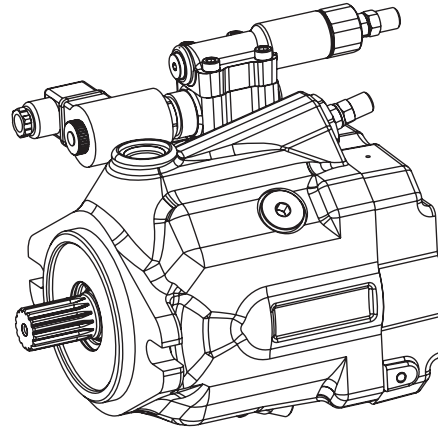

DCAT_048_044

03/06.2011

Pump type	A	B	C	D	E
	mm (in)	mm (in)	mm (in)	mm (in)	mm (in)
MVP 30	202 (7.9528)	104 (4.0945)	89 (3.5039)	130 (5.1181)	99 (3.8976)
MVP 48	222 (8.7402)	110 (4.3307)	94 (3.7008)	137 (5.3937)	105 (4.1339)
MVP 60	227 (8.9370)	110 (4.3307)	94 (3.7008)	137 (5.3937)	105 (4.1339)

Y: Connector. Standard type DIN 43 650 / ISO 4400. For other connectors please consult our technical sales department.

NOTES

03/06.2011

MULTIPLE PUMPS

THROUGH DRIVE

MVP through drive axial piston pumps offer the flexibility to obtain different groups able to supply several hydraulic systems. The operating characteristics of each assembled pumps are the same as the corresponding single pumps according to the following conditions:

- 1) Do not exceed the maximum transmissible torque.
- 2) The maximum rotational speed is that of the lowest rated speed of the single unit incorporated.

M	Nm (lbf in)	Torque
V	cm ³ /rev (in ³ /rev)	Displacement
Δp	bar (psi)	Pressure
$\eta_{hm} = \eta_{hm}(V, \Delta p, n)$		Hydro-mechanical efficiency

$$M = \frac{\Delta p \text{ (bar)} \cdot V \text{ (cm}^3\text{/rev)}}{62,83 \cdot \eta_{hm}} \quad [\text{Nm}]$$

Notes: The torque absorbed from the shaft of the first pump results from the sum of the torques due to all the single stages. The achieved value must not exceed the maximum torque limit given for the shaft of the first pump.

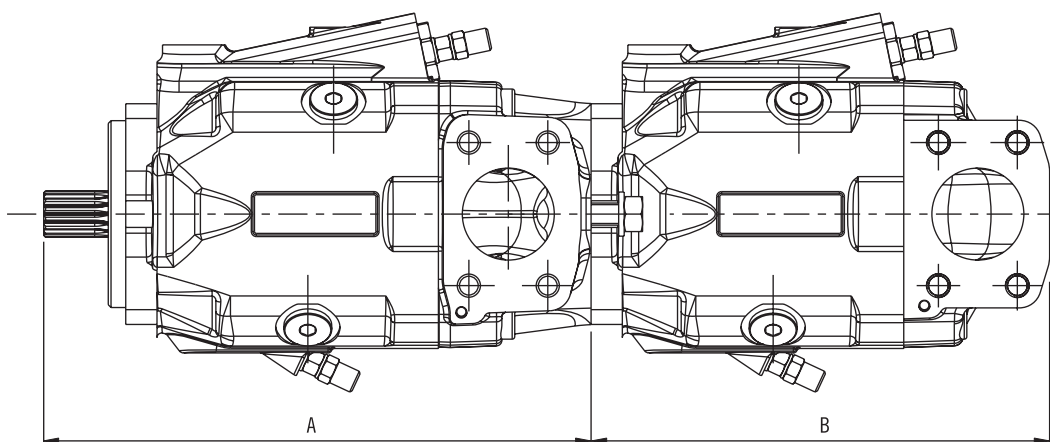

A: Front section (through drive)
B: Rear pump (the same of single pump)

03/06.2011

	A		B	
Pump type	Flanged for	Code	Rear pump (●)	
MVP 48	SAE B	AS5	MVP 30 (S5)	
			MVP 48 (S5)	
			MVP 60 (S5)	
MVP 60	SAE B	AS5	MVP 30 (S5)	
			MVP 48 (S5)	
			MVP 60 (S5)	

(●) The same of single pumps with side or rear ports

MVP48

FRONT SECTION - DIMENSIONS

AS5

Through drive SAE B

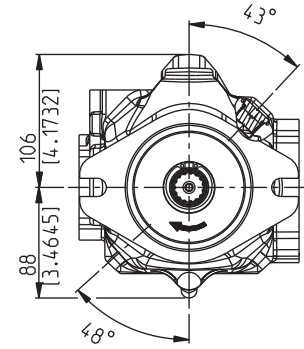
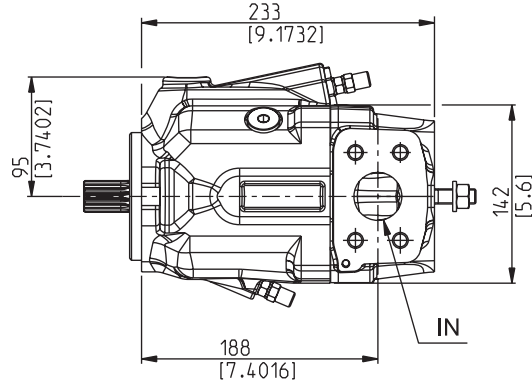
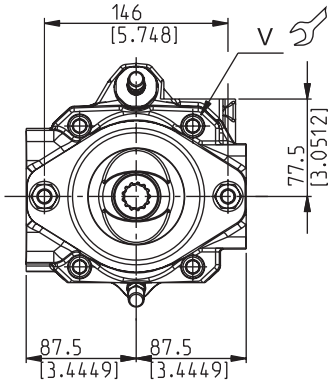

Drive shafts: page 26
Mounting flanges: page 26

DCAT_048_038

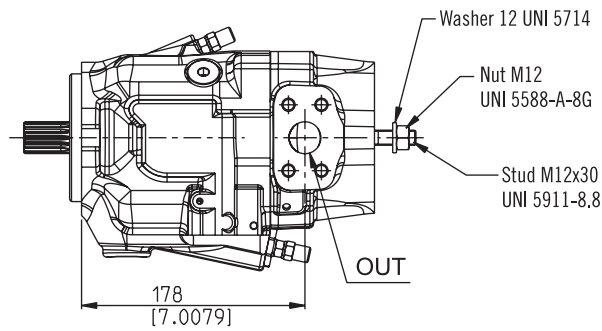
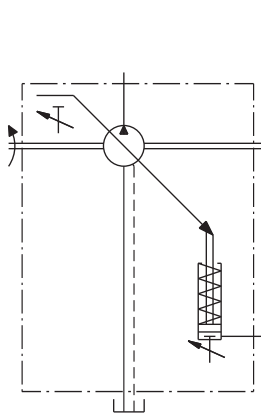
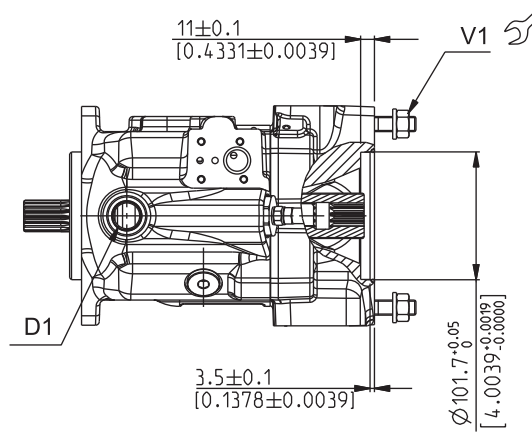

Screws tightening torque Nm (lbf in)

V	V1
100 ±10 (797 ÷ 974)	100 ±10 (797 ÷ 974)

Ports (Nominal size)

IN	OUT	D1
1" 1/2	1"	Drain port

Dimensions at page 32

03/06.2011

MVP48

COUPLINGS - DIMENSIONS

SAE "B" SPLINE

04

Available with flange code **AS5**

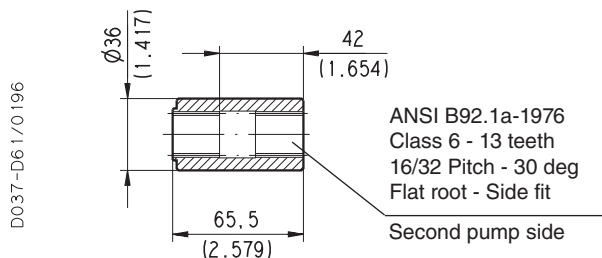

MAX 250 Nm (2213 lbf in)

SAE "BB" SPLINE

05

Available with flange code **AS5**

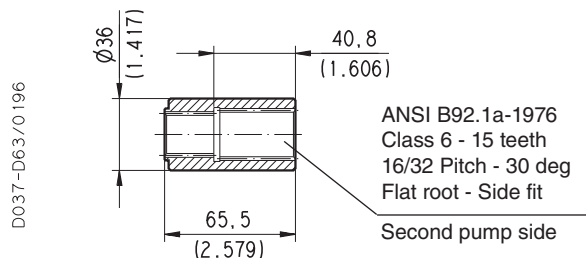

MAX 250 Nm (2213 lbf in)

SAE "B" STRAIGHT

32

Available with flange code **AS5**

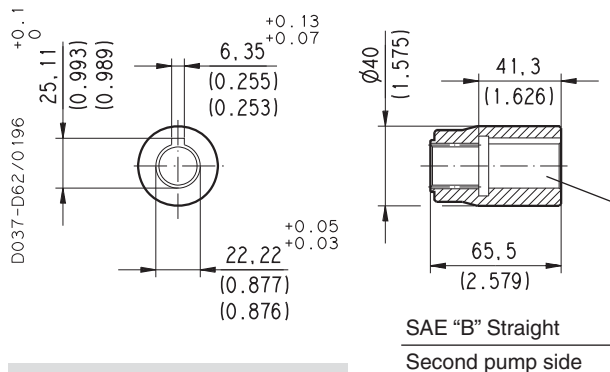

MAX 180 Nm (1593 lbf in)

SAE "BB" STRAIGHT

33

Available with flange code **AS5**

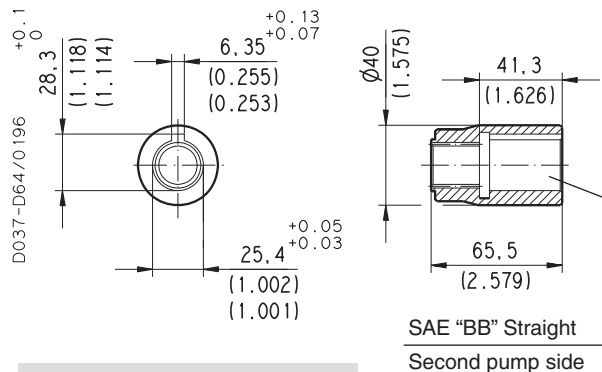

MAX 250 Nm (2213 lbf in)

03/06.2011

MVP60

FRONT SECTION - DIMENSIONS

AS5

Through drive SAE B

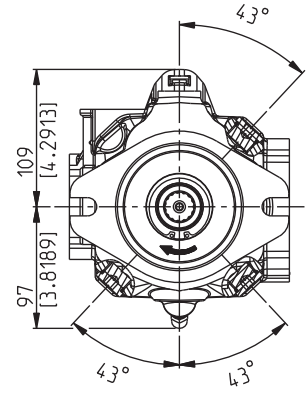
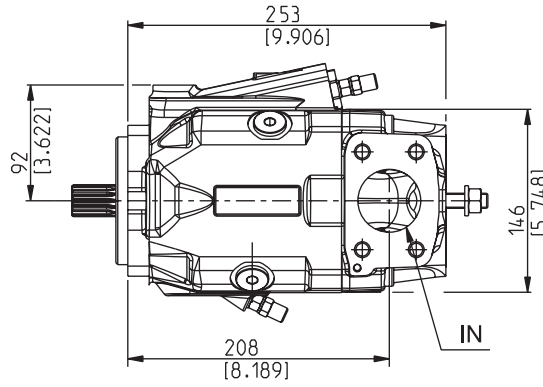
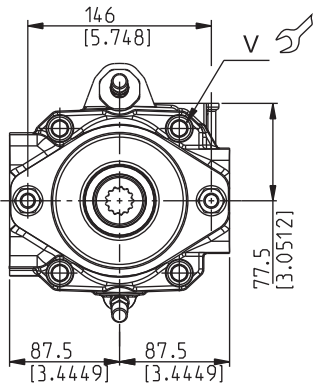

Drive shafts: page 26
Mounting flanges: page 26

DCAT_048_040

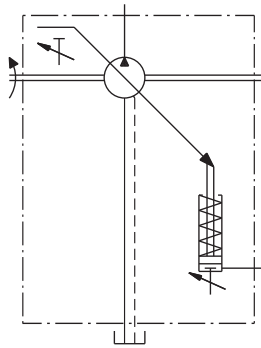
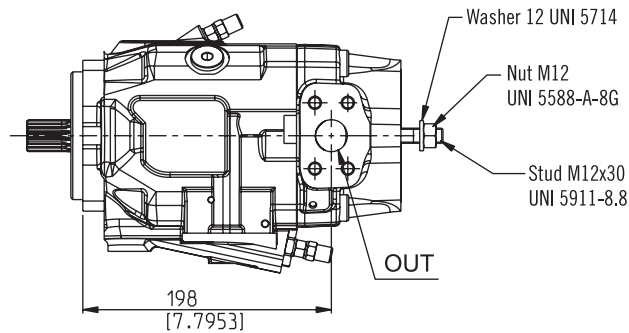
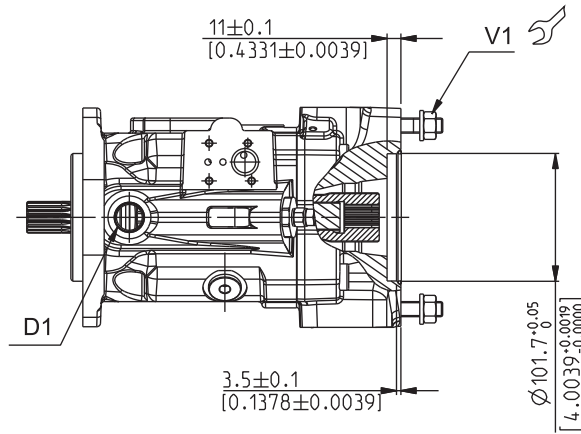

Screws tightening torque Nm (lbf in)

V	V1
130 ±13 (1036 ÷ 1266)	100 ±10 (797 ÷ 974)

Ports (Nominal size)

IN	OUT	D1
2	1"	Drain port

Dimensions at page 32

03/06.2011

MVP60

COUPLINGS - DIMENSIONS

SAE "B" SPLINE

04

Available with flange code **AS5**

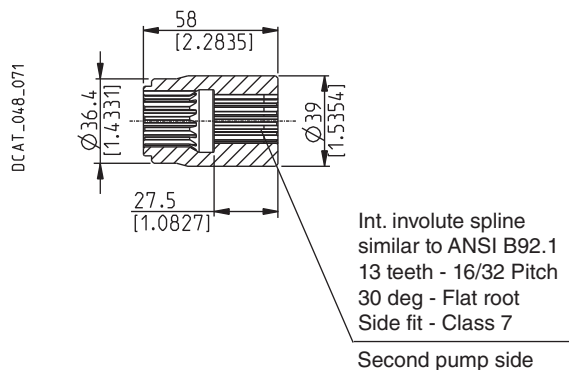

MAX 250 Nm (2213 lbf in)

SAE "BB" SPLINE

05

Available with flange code **AS5**

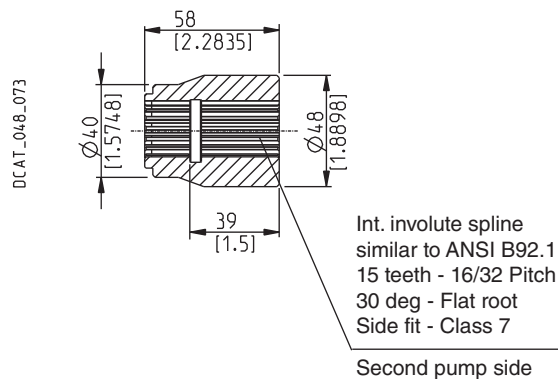

MAX 430 Nm (3806 lbf in)

SAE "C" SPLINE

06

Available with flange code **AS5**

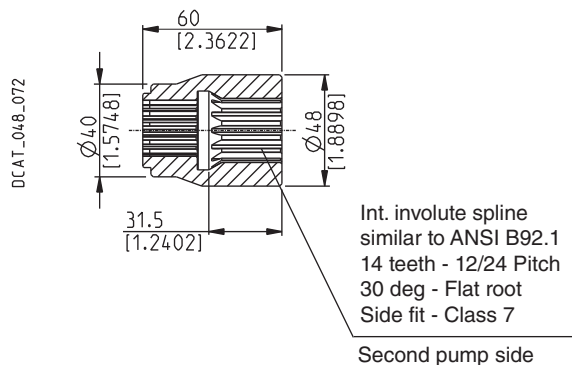

MAX 430 Nm (3806 lbf in)

03/06.2011

FRONT SECTION KIT COVER

Kit cover is available to obtain single pumps starting from the front sections of multiple pumps.
Before closing the intermediate flange check that the coupling has been removed.

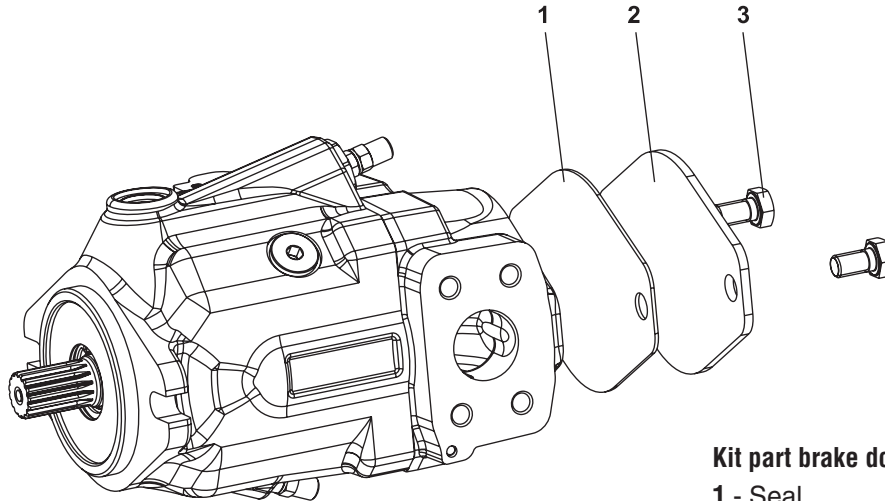

Kit part brake down

- 1 - Seal
- 2 - Flange
- 3 - Screws

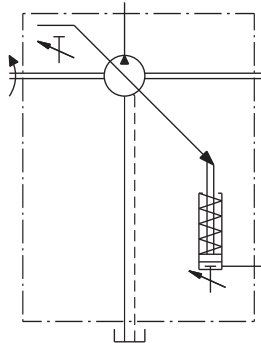

DCAT_048_074

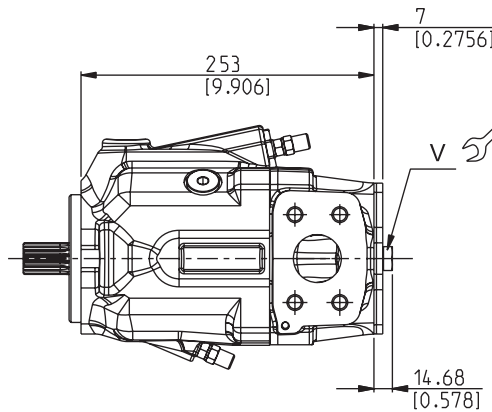

Front section		Kit cover	
Pump type	Flanged for	Code	Code
MVP 48	SAE B	AS5	62082300
MVP 60			

Screws tightening torque Nm (lbf in)

V
20 ±1 (159 ÷ 195)

03/06.2011

HOW TO ORDER SINGLE PUMPS

1	2	3	4	5	6	7	8 ...
MVP30-28	S	-	04	S5	-	L	MD/MB - N - ...

1	Pump type (max. displacement)	Code
	28 cm ³ /rev (1.74 in ³ /rev)	MVP 30-28
	34,8 cm ³ /rev (2.12 in ³ /rev)	MVP 30-34
	45 cm ³ /rev (2.75 in ³ /rev)	MVP 48-45
	53,7 cm ³ /rev (3.28 in ³ /rev)	MVP 48-53
	60 cm ³ /rev (3.66 in ³ /rev)	MVP 60-60
	72 cm ³ /rev (4.39 in ³ /rev)	MVP 60-72
	84,7 cm ³ /rev (5.17 in ³ /rev)	MVP 60-84

2	Rotation	Code
	Anti-clockwise	S
	Clockwise	D

3	Drive shaft (a)	Code
	SAE "B" spline (13 teeth)	04
	SAE "B" straight	32
	SAE "BB" spline (15 teeth)	05
	SAE "C" spline (14 teeth)	06
	SAE "C" straight	34

4	Mounting flange (a)	Code
	SAE "B" 2 holes	S5
	SAE "C" 4 holes	S8

5	Ports position	Code
	Side	L
	Rear	P

Code	Inlet/outlet ports		6
	Nominal size		
	Inlet IN	Outlet OUT	Pump type
	SAE 3000	SAE 3000	
SAE FLANGED PORTS METRIC THREAD (SSM)			
MD/MB	1" 1/4	3/4"	MVP 30
ME/MC	1" 1/2	1"	MVP 48
MF/MC	2"	1"	MVP 60
SAE FLANGED PORTS UNC THREAD (SSS)			
SD/SB	1" 1/4	3/4"	MVP 30
SE/SC	1" 1/2	1"	MVP 48
SF/SC	2"	1"	MVP 60
SAE STRAIGHT THREAD PORTS (ODT)			
	—	—	MVP 30
OH/OF	1" 1/2	1"	MVP 48
MF/OF	2"	1"	MVP 60

Code	Seals	7
N	Buna (standard)	
V	Viton	

Code	Regulators	8
...	See how to order on page 58 ÷ 60	

- (a) Drive shafts/mounting flanges availability:
 MVP30 on page 21
 MVP48 on page 26
 MVP60 on page 31

03/06.2011

HOW TO ORDER REGULATORS

PRESSURE COMPENSATORS - FLOW COMPENSATORS (Load-sensing)

	8	9	10	11	12	13
Pressure compensator	RP0 -					G
Pressure compensator	RP1 -					G
Pressure compensator with flow control	RP1 -		LS2 -			G
Dual setting pressure compensator	RP2 -	1 -			S -	G
Dual setting pressure compensator with flow control	RP2 -	1 -	LS2 -	Z -	S -	G
Flow compensator	LS0 -			Z -		G
Flow compensator for remote control	LS2 -			Z -		G
Pressure compensator for remote control	LS3 -			Z -		G

8	Regulators type	Code
	Pressure compensator	RP0
	Pressure compensator	RP1
	Dual setting pressure compensator	RP2
	Flow compensator	LS0
	Flow compensator for remote control	LS2
	Pressure compensator for remote control	LS3

9	Valve type (a)	Code
	Normally closed 12 VDC	1
	Normally closed 24 VDC	2
	Normally closed 24 VAC	3
	Normally open 12 VDC	6
	Normally open 24 VDC	7
	Normally open 24 VAC	8

Code	Flow control option (b)	10
LS2	Flow compensator	

Code	Restrictor option (c)	11
	Without restrictor (standard - no code)	
Z	Damping restrictor (only for critical applications)	

Code	Connector type (a)	12
S	DIN 43 650 / ISO 4400 (standard)	
D	Deutsch	
J	Junior-Timer	

Code	Displacement limiter	13
G	Min. and Max. displacement limiter	

03/06.2011

ORDER EXAMPLE

MVP60 pump with dual setting pressure compensator:

MVP60.60S-05S5-LMF/MC-N-RP2-1-S-G

- (a) Only for RP2
- (b) Only for RP1 and RP2
- (c) Only for RP2 with flow control, LS0, LS2 and LS3

HOW TO ORDER REGULATORS

TORQUE LIMITERS

	8	9	10	11	12	13	14	15	16								
Torque limiter - standard	RN0	-			Z	-	G	-	...	/			...				
Torque limiter - internal pilot	RN1	-					G	-	...	/			...				
Dual setting torque limiter with flow control	RN2	-	1	-	S	-	LS0	-	Z	-	G	-	...	/	...	/	...
Dual setting torque limiter with remote flow control	RN2	-	1	-	S	-	LS2	-	Z	-	G	-	...	/	...	/	...

8	Regulators type	Code
	Torque limiter - standard	RN0
	Torque limiter - internal pilot	RN1
	Dual setting torque limiter with flow control	RN2

9	Valve type (a)	Code
	Normally closed 12 VDC	1
	Normally closed 24 VDC	2
	Normally open 12 VDC	6
	Normally open 24 VDC	7

10	Connector type (a)	Code
	DIN 43 650 / ISO 4400 (standard)	S
	Deutsch	D
	Junior-Timer	J

Code	Flow control option (a)	11
LS0	Flow compensator	
LS2	Flow compensator for remote control	

Code	Restrictor option (b)	12
	Without restrictor (standard - no code)	
Z	Damping restrictor (only for critical applications)	

Code	Displacement limiter	13
G	Min. and Max. displacement limiter	

Code	Torque limiter setting (c)	14
...	Please specify the requested torque value in Nm	

Code	Second torque limiter setting (a) - (c)	15
...	Please specify the requested torque value in Nm	

Code	Torque limiter setting speed (d)	16
...	Please specify the requested speed value	

- (a) Only for RN2
- (b) Only for RN0 and RN2
- (c) Refer to page 46 for more information
- (d) Do not exceed the maximum speed shown on page 5 ÷ 7

ORDER EXAMPLE

MVP60 pump with dual setting torque limiter with flow control:

MVP60.60S-05S5-LMF/MC-N-RN2-1-S-LS0-Z-G-150/200/2100

03/06.2011

HOW TO ORDER REGULATORS

ELECTRO-PROPORTIONAL PRESSURE COMPENSATORS - UNLOADING VALVES

	8	9	10	11	12	13	14	15	16				
Electro-proportional pressure compensator	PEC	1	A	-		...	/	...	-	S	-	G	
Electro-proportional pressure compensator with flow control	PEC	1	A	-	LS2	-	...	/	...	-	S	-	G
Unloading valve	U..	-			Z	-						G	

8	Regulators type	Code
	Electro-proportional pressure compensator	PEC
	Unloading valve - Normally closed 12 VDC	U1
	Unloading valve - Normally closed 24 VDC	U2
	Unloading valve - Normally closed 24 VAC	U3
	Unloading valve - Normally closed 110 VAC	U4
	Unloading valve - Normally closed 220 VAC	U5
	Unloading valve - Normally open 12 VDC	U6
	Unloading valve - Normally open 24 VDC	U7
	Unloading valve - Normally open 24 VAC	U8
	Unloading valve - Normally open 110 VAC	U9
	Unloading valve - Normally open 220 VAC	U10

9	Valve type (a)	Code
	Normally closed 12 VDC	1
	Normally closed 24 VDC	2
	Normally open 12 VDC	6
	Normally open 24 VDC	7

10	Position (a)	Code
	Position 0°	A
	Position 90°	B

Code	Flow control option (b)	11
LS2	Flow compensator for remote control	

Code	Restrictor option (c)	12
	Without restrictor (standard - no code)	
Z	Damping restrictor (only for critical applications)	

Code	Min. pressure setting (a)	13
...	Setting range 25 ÷ 100 bar	

Code	Max. pressure setting (a)	14
...	Setting range 210 ÷ 310 bar	

Code	Connector type (a)	15
S	DIN 43 650 / ISO 4400 (standard)	
D	Deutsch	
J	Junior-Timer	

Code	Displacement limiter	16
G	Min. and Max. displacement limiter	

- (a) Only for PEC
(b) Only for PEC with flow control
(c) Only for U.. unloading valve

ORDER EXAMPLE

MVP60 pump with electro-proportional pressure compensator with flow control:

MVP60.60S-05S5-LMF/MC-N-PEC-1-A-LS2-100/300-S-G

03/06.2011

HOW TO ORDER MULTIPLE PUMPS - PISTON PUMP/GEAR PUMP

1	2	3	4	5	6	7	8 ...	9	10	11	12
MVP30-28	S	- 04	S5	- L	MD/MB	- N	- ...	- G	/		
Front section											

KP20-6,3	-	-	L	**GD	-	...	/	...	/	...	
Rear section						Torque limiter setting					

1	Pump type (max. displacement)	Code
	Front section - The same of single pumps	MVP ...
	Rear section - KAPPA 20 gear pumps (a)	KP 20 ...
	Rear section - POLARIS PH gear pumps (b)	PHP 20 ...

2	Rotation	Code
	Anti-clockwise	S
	Clockwise	D

3	Drive shaft (c)	Code
	SAE "B" spline (13 teeth)	04
	SAE "B" straight	32
	SAE "BB" spline (15 teeth)	05
	SAE "C" spline (14 teeth)	06
	SAE "C" straight	34

4	Mounting flange (c)	Code
	SAE "B" 2 holes	S5
	SAE "C" 4 holes	S8

5	Ports position	Code
	Side	L

- (a) KAPPA 20 gear pumps: displacements on page 19, 24 and 29. For more information, please see the respective technical catalogue
- (b) POLARIS PH gear pumps displacements on page 20, 25 and 30. For more information, please see the respective technical catalogue
- (c) Drive shafts/mounting flanges availability:
MVP30 on page 21
MVP48 on page 26
MVP60 on page 31
- (d) Only for torque limiter. Refer to page 59 for more information

Code	Inlet/outlet ports	6
	Nominal size	
	Inlet IN	Outlet OUT
	SAE 3000	SAE 3000

SAE FLANGED PORTS METRIC THREAD (SSM)

MD/MB	1" 1/4	3/4"	MVP 30
ME/MC	1" 1/2	1"	MVP 48
MF/MC	2"	1"	MVP 60

SAE FLANGED PORTS UNC THREAD (SSS)

SD/SB	1" 1/4	3/4"	MVP 30
SE/SC	1" 1/2	1"	MVP 48
SF/SC	2"	1"	MVP 60

SAE STRAIGHT THREAD PORTS (ODT)

**/OC	—	5/8"	KP 20 / PHP 20
	—	—	MVP 30
OH/OF	1" 1/2	1"	MVP 48
MF/OF	2"	1"	MVP 60

GAS STRAIGHT THREAD PORTS (BSPP)

**GD	—	1/2"	KP 20 / PHP 20
-------------	---	------	----------------

Code	Seals	7
N	Buna (standard)	
V	Viton	

Code	Regulators	8
...	See how to order on page 58 ÷ 60	

Code	Displacement limiter	9
G	Min. and Max. displacement limiter	

Code	Torque limiter setting (d)	10
...	Please specify the requested torque value in Nm	

Code	Second torque limiter setting (d)	11
...	Please specify the requested torque value in Nm	

Code	Torque limiter setting speed (d)	12
...	Please specify the requested speed value	

03/06.2011

HOW TO ORDER MULTIPLE PUMPS - PISTON PUMP/PISTON PUMP

1	2	3	4	5	6	7	8 ...	9	10	11	12	13	14	
MVP 60-60	S	- 05	S5	- L	MF/MC	- N	- ...	- G	- AS5	- 04	- ...	/ ...	/ ...	/ ...
Front section (through drive)														

MVP 30-28	S	- 04	S5	- L	MD/MB	- N	- ...	- G	-	-	- ...	/ ...	/ ...	/ ...
Rear section (single pump)														

1	Pump type (max. displacement) (a)	Code
Front section - MVP 48 and MVP 60		MVP ...
Rear section - The same of single pumps		MVP ...

2	Rotation	Code
Anti-clockwise		S
Clockwise		D

3	Drive shaft (b)	Code
SAE "B" spline (13 teeth)		04
SAE "B" straight		32
SAE "BB" spline (15 teeth)		05
SAE "C" spline (14 teeth)		06
SAE "C" straight		34

4	Mounting flange (b)	Code
SAE "B" 2 holes		S5
SAE "C" 4 holes		S8

5	Ports position	Code
Side		L
Rear (Only for rear section)		P

6	Inlet/outlet ports	Code	
Nominal size			
Pump type	Inlet IN	Outlet OUT	
	SAE 3000	SAE 3000	
SAE FLANGED PORTS METRIC THREAD (SSM)			
MVP 30	1" 1/4	3/4"	MD/MB
MVP 48	1" 1/2	1"	ME/MC
MVP 60	2"	1"	MF/MC
SAE FLANGED PORTS UNC THREAD (SSS)			
MVP 30	1" 1/4	3/4"	SD/SB
MVP 48	1" 1/2	1"	SE/SC
MVP 60	2"	1"	SF/SC
SAE STRAIGHT THREAD PORTS (ODT)			
MVP 30	—	—	
MVP 48	1" 1/2	1"	OH/OF
MVP 60	2"	1"	MF/OF

Code	Seals	7
N	Buna (standard)	
V	Viton	

Code	Regulators	8
...	See how to order on page 58 ÷ 60	

Code	Displacement limiter	9
G	Min. and Max. displacement limiter	

Code	Intermediate flange (c)	10
AS5	SAE "B" 2 holes	

Code	Coupling (d)	11
04	SAE "B" spline (13 teeth)	
32	SAE "B" straight	
05	SAE "BB" spline (15 teeth)	
33	SAE "BB" straight	
06	SAE "C" spline (14 teeth)	

Code	Torque limiter setting (e)	12
...	Please specify the requested torque value in Nm	

Code	Second torque limiter setting (e)	13
...	Please specify the requested torque value in Nm	

Code	Torque limiter setting speed (e)	14
...	Please specify the requested speed value	

- (a) Displacements on page 57
- (b) Drive shafts/mounting flanges availability:
MVP30 on page 21
MVP48 on page 26
MVP60 on page 31
- (c) Intermediate flanges on page 51
- (d) Couplings availability:
MVP48 on page 53
MVP60 on page 31
- (e) Only for torque limiter. Refer to page 59 for more information

03/06.2011

Our policy is one of continuous improvement in product. Specification of items may, therefore, be changed without notice.

MVP 04 T A

Edition: 04/01.2012

Replaces: MVP 03 T A



Headquarters:
CASAPPA S.p.A.
Via Balestrieri, 1
43044 Lemignano di Collecchio
Parma (Italy)
Tel. (+39) 0521 30 41 11
Fax (+39) 0521 80 46 00
IP Videoconferencing
E-mail: info@casappa.com
www.casappa.com

